

M T H E L E C T R I C T R A I N S

1998 VOLUME III

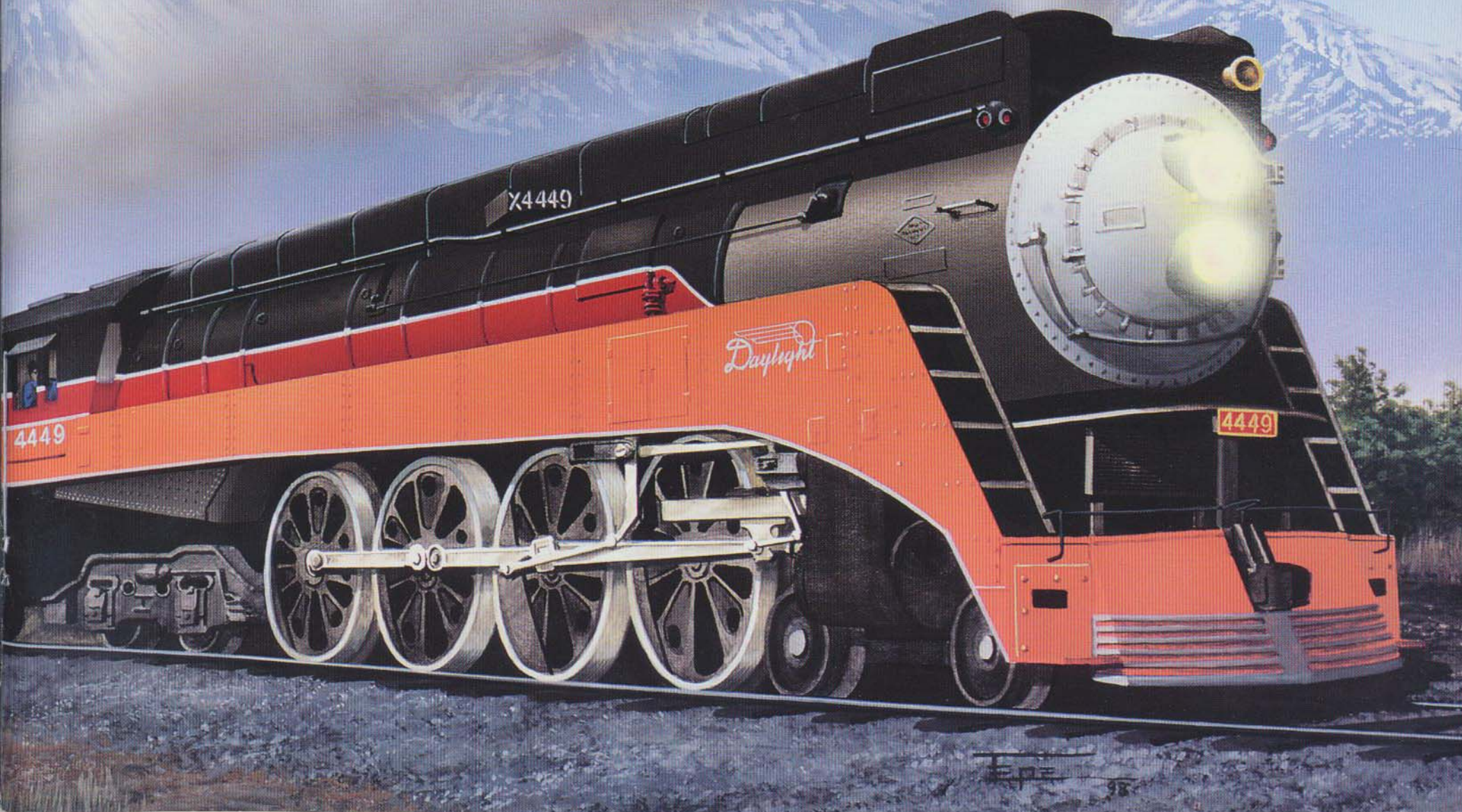

TABLE OF CONTENTS

ON-TRACK

WELCOME TO MTH

Introduction Letter	2
Proto-Sound® Explanation	4

RAILKING® LINE

NW-2 Diesel Switcher Locomotive	8
4-6-2 K-4s Steam Locomotive	10
4-6-2 Forty-Niner Steam Locomotive	12
4-8-4 Northern Steam Locomotive	14
Ready-To-Run Set	16
O-27 4-Car Passenger Sets	17
O-27 2-Car Superliner Sleeper/Diner Sets	18
O-27 Madison & Streamlined Combine/Diner Sets	19
Semi-Scale Rolling Stock	20

PREMIER LINE

GP38-2 Diesel Locomotive	24
SD-90MAC & SD-80 Diesel Locomotives	26
4-8-4 Gs-4 Steam Locomotive	28
Scale Genesis Diesel & Superliner Set	30
70' 2-Car Scale Passenger Sets	32
'O' Scale Rolling Stock	34
Z-1000™	37

TINPLATE TRADITIONS

302E Steam Engine & Tender	40
Freight & Accessories	42

RAILKING® ACCESSORIES

Rolling Stock Accessories	46
MTH RiteTrax® Track System	47
Operating Accessories	50
Layout Accessories	52
Railcessories	54
Proto-Sound® Products	55

MTH Electric Trains' success over the last five years was wrought by listening to what our customers had to say. Without your input, our success would surely have been limited and our growth restricted.

Naturally, not everything that we have produced over the years has appealed to every train enthusiast in the same way, a testimony to the personal preferences of model railroaders. Yet, when we step back and look at the sheer variety of merchandise we have produced in this short period of time, we can't help but be proud of the joy and happiness these items have brought to O Gauge enthusiasts everywhere.

How important are your suggestions and comments? Simply put, without them it is unlikely we would have introduced 35 steam locomotives and over 44 new diesel engines since 1993 - not to mention the dozens of rolling stock, passenger cars and layout accessories we have released. In other words, MTH owns

more new motive power tooling than all other O Gauge manufacturers have produced in their combined history - a history spanning over 150 years! Remarkably, MTH has accomplished this feat in just five short years.

Despite these accomplishments, you won't find a sense of complacency within our walls. Instead, look for a sustained effort by everyone at MTH to continue improving your perception of MTH Electric Trains, not only in the pages of this and other catalogs, but throughout the MTH organization. For example, the first edition of our parts catalog is now available through your local MTH retailer with subsequent editions to follow in the second half of the year. In addition, many of the parts diagrams will find their way to our web site where they can be easily downloaded and printed. Our service department will continue to undergo improvements and enhancements - in the form of new staff as well as in the manner each and every service inquiry is handled and processed. Finally, and perhaps most importantly, refinements to our production facilities will lead to improved quality control standards - standards that we feel are already the highest in the industry.



Perhaps the most obvious changes we're making in 1998 are to our diesel lineups. Not only will you find lower prices up to \$100.00 off the MSRP in both our RailKing and Premier Line diesel engines, but more detail as well. Premier

engines will feature all-new spinning roof fans, lighted number boards, lighted marker lights or ditch lights, stainless steel grills and painted handrails as well as all the standard features you've come to expect on Premier Line diesel engines. We've added all these features and lowered prices so that you can make head-to-head comparisons with MTH products and those of our competitors. We're convinced you'll find MTH to be superior in every aspect.

Visit your local MTH dealer or our website today and see for yourself why MTH Electric Trains is O Gauge railroading's most innovative manufacturer.

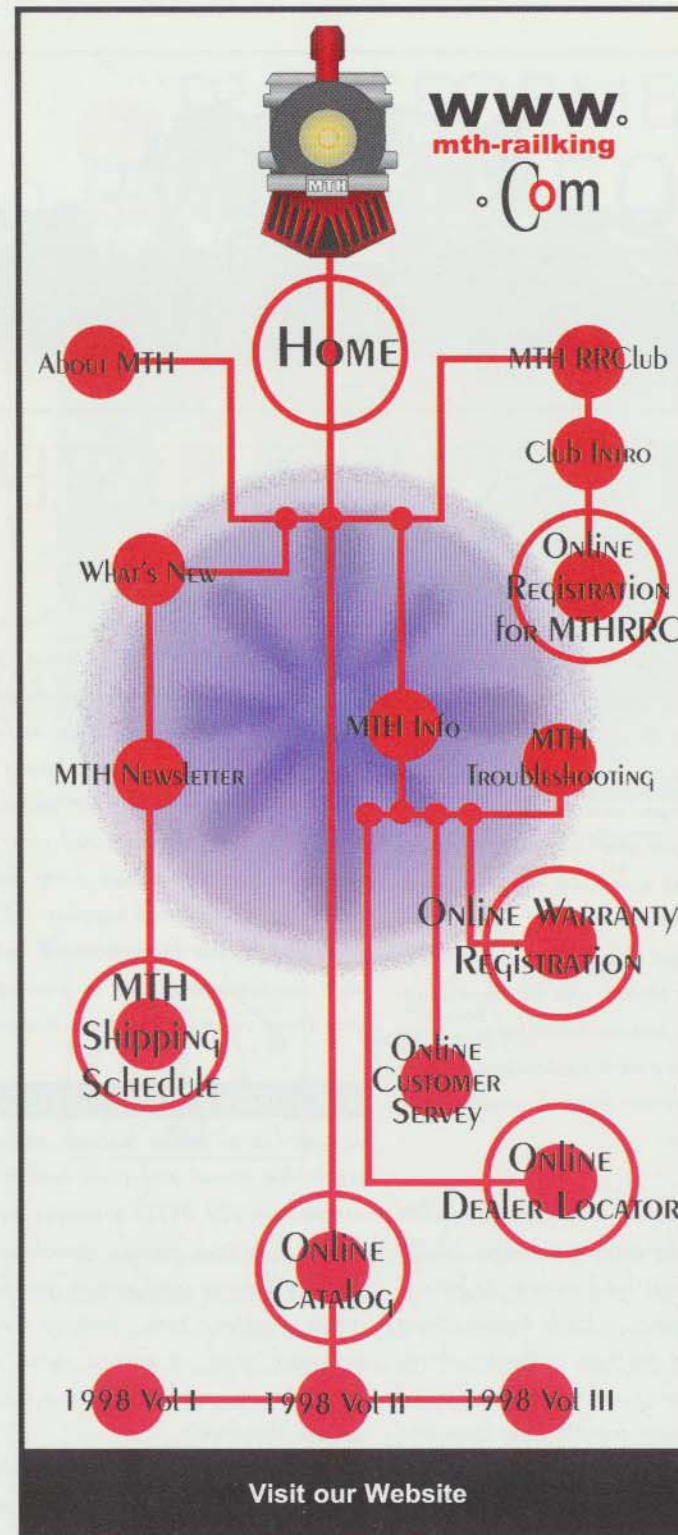
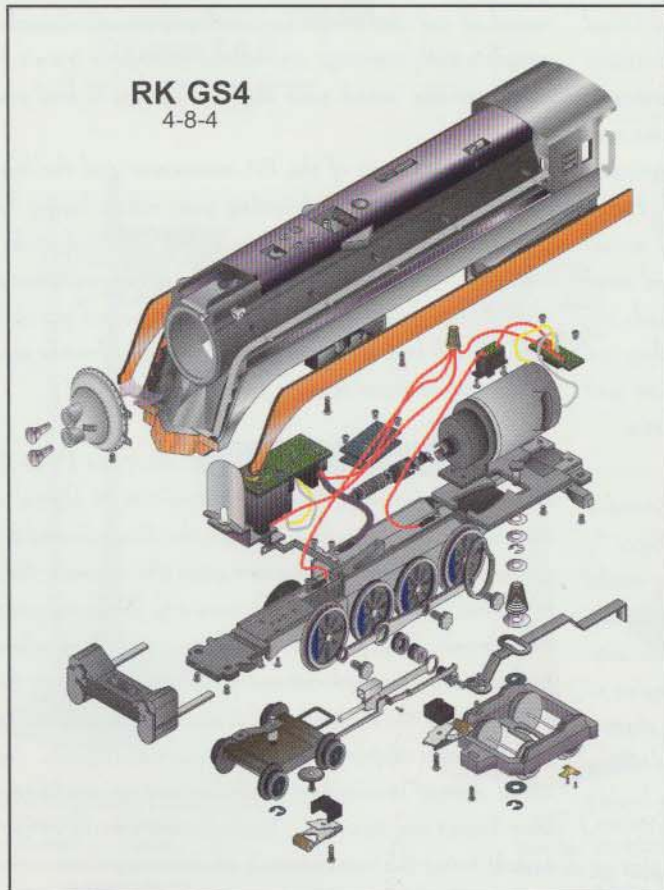

INTRODUCTION

MTH

PAGE 3



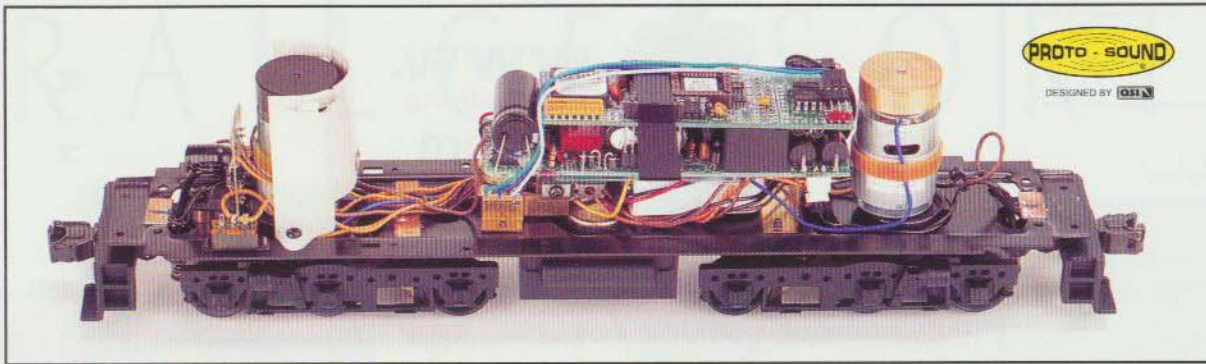

THE PROTO-SOUND® SYSTEM

PROTO-SOUND® Now you can order almost every MTH engine with the exciting MTH Proto-Sound® system: a state-of-the-art digital sound and train control system that requires no additional equipment or wiring to your layout. You simply hook up any compatible transformer and begin experiencing the digital world of model railroading.

To operate Proto-Sound®, just put your engine on the track - right out of the box. As soon as you power-up your transformer, you will hear the authentic sounds of your diesel, steam or electric engine awaken as it awaits your command to start moving. Your transformer's throttle and its whistle button activate all the Proto-Sound® features listed below. There is no need to purchase a whole new control system with dozens of buttons and keystrokes to memorize; Proto-Sound® works with almost any A.C. transformer.

CD-LIKE QUALITY When ordered with Proto-Sound®, your RailKing or Premier Line locomotive contains 16-Bit high quality digital sounds you just have to hear to believe! Take for example our steam engines. Each engine comes equipped with synchronized steam chuffing, authentic whistle and bell sounds, air compressor pump and let-off sounds, and randomly activated sounds like steam pop-off, blow down and injector sounds. Even when sitting still, a Proto-Sound® equipped MTH steam engine sounds like it's alive and breath-

ing - just like the real thing. Proto-Sound® equipped Diesel engines sport many of the same sound qualities as their steam brethren, including 8 levels of diesel motor sound, authentic sounding horn and bell sounds, and air compressor pump and let-off sounds. Additionally, every Proto-Sound® equipped diesel also comes with our exclusive Cab Chatter Proto-Effects™ - digitally captured radio transmissions of actual engineers and dispatchers going about the business of train switching, loading and hopping. Best of all these sounds are controlled by the Proto-Sound® microprocessor, so they are each randomly activated to prevent constant repetition and give Proto-Sound® owners a true-to-life sound experience.

EXCLUSIVE PROTO-EFFECTS™ Every Proto-Sound® equipped engine also features our exclusive Proto-Effects™, true-to-life sound and train control effects that make model railroading with MTH a unique and fun experience. Proto-Effects™ sounds include squeaking brakes that, when activated, will pierce your ears as you throttle down the engine to a stop or enter a turn. Imagine the fun of entering a station or switch yard, or even a curve after highballing down a straightaway and hearing the sound of your engine's brakes as you slowdown.

But there's even more! With Proto-Effects™ you also get special sounds for your freight or passenger engine that you

won't find anywhere else. When the Proto-Effects™ are activated, your freight line steam or diesel engine will play special freight yard sounds once the engine comes to a halt. The freight yard Proto-Effects™ sounds include sliding box car doors, thumping pallet sounds, forklift truck sounds (including the ever present warning bell) and colorful cab chatter that provides a sort of railroading play-by-play of the freight yard activities as they unfold. It's simply amazing and loads of fun.

The Proto-Effects™ sound in your passenger line steam and diesel Proto-Sound® equipped engines truly brings a level of unmatched realism to your model railroad. Imagine your wonderment as your engine glides to a stop at your passenger station platform to be greeted with a public address announcing its arrival. The announcement is quickly followed by the sound of car doors opening and passengers disembarking, complete with warnings and advice from your train's friendly conductor like "watch your step" and where to find your baggage.

The booming voice of the PA announcer and the hastening pace of the passengers boarding your rolling luxury liner are some of the background sounds you will find with Proto-Sound®. We've even thrown in the age-old conductor cry "all aboard" just before the train begins its slow roll out of the station. You'll find that you, your family and friends just can't get enough of these exciting features.

A COMPUTER ON BOARD All of the Proto-Effect™ sounds and features, like the Proto-Sound® digital sounds themselves, are controlled through the Proto-Sound® microprocessor. This microprocessor gives the operator the ability to control an array of features remotely from any compatible transformer. The features include remote volume adjustment and remote engine lock-out control as well as perhaps the most exciting of all the Proto-Sound® features: remote control over your engine's coupler from anywhere on the layout. No additional wiring, uncoupling track sections or modifications to your layout are required. Each feature can be activated by simply using the transformer's whistle controller.



PROTO-SOUND®

S I M P L E , F U N A N D E A S Y

PROTO-SOUND® FEATURES: DIESEL ENGINES

- Variably Controlled 8 Level Diesel Sound
- Authentic Diesel Horn
- Authentic Diesel Bell
- Squeaking Brakes
- Randomly Activated Cab Chatter Sequences
- Passenger Station or Freight Yard Proto-Effects™
- Remote Controlled Engine Volume Adjustment
- Remote Controlled Engine Lockout Setting
- Operates with any Compatible AC Transformer
- Self-Recharging Battery Backup with Auto Shut-off
- Directionally Controlled Headlights
- Constant Voltage Headlights
- Remote Controlled Die-Cast Metal Proto-Couplers®

DISCOVER
STATE-OF-THE-ART
TECHNOLOGY
AND
BRING REALISM
TO YOUR
RAILROAD

PROTO-SOUND® FEATURES: STEAM ENGINES

- Synchronized Steam Chuffing Sound
- Authentic Steam Whistle
- Authentic Steam Bell
- Air Compressor Pump & Let-off Sounds
- Squeaking Brakes
- Randomly Activated Steam Neutral Sounds
- Passenger Station or Freight Yard Proto-Effects™
- Remote Controlled Engine Volume Adjustment
- Remote Controlled Engine Lockout Setting
- Operates with any Compatible AC Transformer
- Self-Recharging Battery Backup with Auto Shut-off
- Remote Controlled Die-Cast Metal Proto-Couplers®

RAILKING®

MTH ELECTRIC TRAINS



RAILKING

RAIL KING
By MTH Electric Trains



At MTH Electric Trains, we strive to provide our customers with a level of quality and value not seen in toy train manufacturing for decades! Our RailKing line perhaps sums up the MTH philosophy best with our promise to bring back "Quality In The Tradition You Remember."

By striving to produce quality trains at fair prices, we believe you will find MTH products to be better than those produced years ago, or even today, by other manufacturers. By constantly reviewing our own line for possible improvements and enhancements, we make a commitment to provide our customers with the best value model railroading has to offer.

As you thumb through our RailKing offerings, you'll find this commitment in each product featured on the next several pages. For example, every RailKing locomotive, including those offered in our ready-to-run sets, can be ordered with an electronic horn or whistle or our state-of-the-art Proto-Sound® Digital Sound and Train Control System. Designed with the operator in mind, Proto-Sound® is a technological marvel that provides the operator with realistic sound effects and remote control operation over a multitude of railroading tasks. In addition, each RailKing locomotive comes equipped with a die-cast metal chassis, wheels, axles and gears and most feature a flywheel-equipped precision motor for realistic starts, stops and pulling strength.

RailKing - The fun and exciting way to enjoy O Gauge model railroading.



NW 2 DIESEL SWITCHER

Optionally
Equipped
With

PROTO-SOUND

DESIGNED BY

See Page 4 for Details

Proto-Coupler[®]
ON BOARD



Union Pacific - Item No. 30-2138

With over 1,100 produced, the EMD NW2 switcher proved to be one of the most popular switch engines ever manufactured. Constructed over a 10-year period between 1930 and 1949, NW2s performed their switching tasks with great efficiency by utilizing their 1,000hp prime mover that provided plenty of power for even the toughest yard duties.

By popular demand, MTH is proud to announce the addition of the NW2 switcher to the RailKing roster. This mighty workhorse features 2 flywheel equipped motors beneath its durable, intricately detailed ABS shell - all riding atop a metal frame and die cast trucks. All-metal

gears, trucksides and pilots, metal handrails, and metal operating couplers ensure that your NW2 will be running for years.

As with other RailKing locomotives, the NW2 is optionally equipped with the exciting Proto-Sound[®] digital sound and train control system and remotely controlled Proto-Couplers[®] - perfect for authentic switching duties. When idling in a yard and not performing switching duties, your NW2 remains active as evidenced by the ongoing Cab Chatter sounds of the engineer talking to the tower or the bustling sound effects of the freight yard.

nw 2 switcher diesel Features include:

- Operating Headlight
- Die-Cast Truck Sides, Pilots, and Tanks
- Colorful Paint Schemes
- Operates on O-27 Track
- Metal Handrails and Horn
- DCRU[®] Reverse Unit
- 2 Precision Flywheel Equipped Motors
- Optionally Equipped with the Proto-Sound[®] Digital Sound Control with Squeaking Brakes, Freight Yard Proto-Effects[™], and Remote Controlled Proto-Coupler[®]
- Measures Approximately: 11 1/2" x 2 1/2" x 3 3/4"



Chicago Northwestern - Item No. 30-2139

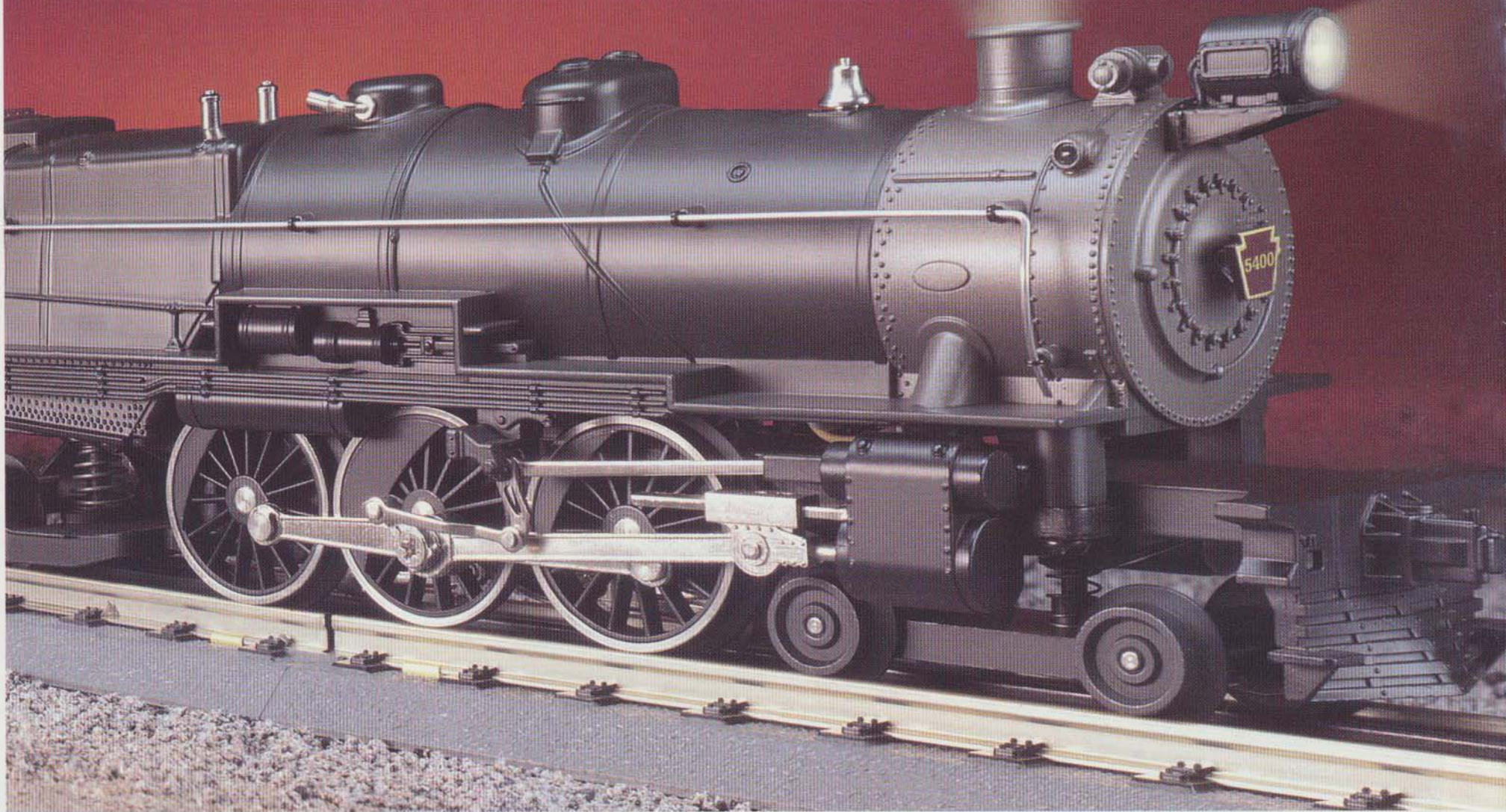

4 - 6 - 2 K - 4 s S T E A M E R



Pennsylvania - Item No. 30-1138

Optionally
Equipped
With



DESIGNED BY GEN

See Page 4 for Details



On perhaps the greatest railroad ever, no steam locomotive was more revered than the legendary Pennsylvania K-4s Pacific. Evolved from a program begun in 1914 to develop heavy freight and passenger classes utilizing common boiler designs, the K-4s was an instant success. From 1917 to 1928, the PRR built a total of 425 units in the Juanita and Baldwin Shops.

The 4-6-2 K-4s became the Pennsylvania's principal passenger hauler, possessing a consummate blend of speed and power. Often double headed on East Coast Limiteds pulling a Pullman consist, the K-4s was a common and beautiful sight on the Pennsylvania's rails and deservedly became synonymous with that railroad's steam power.

MTH Electric Trains is proud to bring the beautiful RailKing K-4s to life on your traditionally sized O gauge layout. With its precision flywheel equipped motor, the K-4s provides smooth operation from a super slow crawl to a high-speed express. Witness the voluminous smoke output from the amazing ProtoSmoke® system and you'll swear you're seeing the real thing. A closer inspection of the highly detailed boiler and tender, metal chassis and running gear, and realistic cab detail combined with the optional Proto-Sound® digital sound and train control system will further cement the fact in your mind that the RailKing K-4s is one of the finest O Gauge steam locomotives you could own.

4-6-2 K-4s LOCOMOTIVE FEATURES INCLUDE:

- Die-Cast Boiler and Tender
- Spoked Metal Drivers
- Metal Handrails and Decorative Whistle
- Precision Flywheel Equipped Motor
- Operating Headlight
- Operates on O-27 Track
- Detailed Cab Interior
- DCRU® Reversing Unit
- Operating Metal Coupler
- Operating ProtoSmoke® System
- Optionally Equipped with Proto-Sound® Digital Sound and Train Control, Passenger Station Proto-Effects™ and Remote Controlled Proto-Coupler®
- Measures Approximately:
19 3/4" x 2 5/8" x 3 1/2"

4 - 6 - 2 K - 4 s STEAMER





4-6-2 FORTY-NINER STEAMER

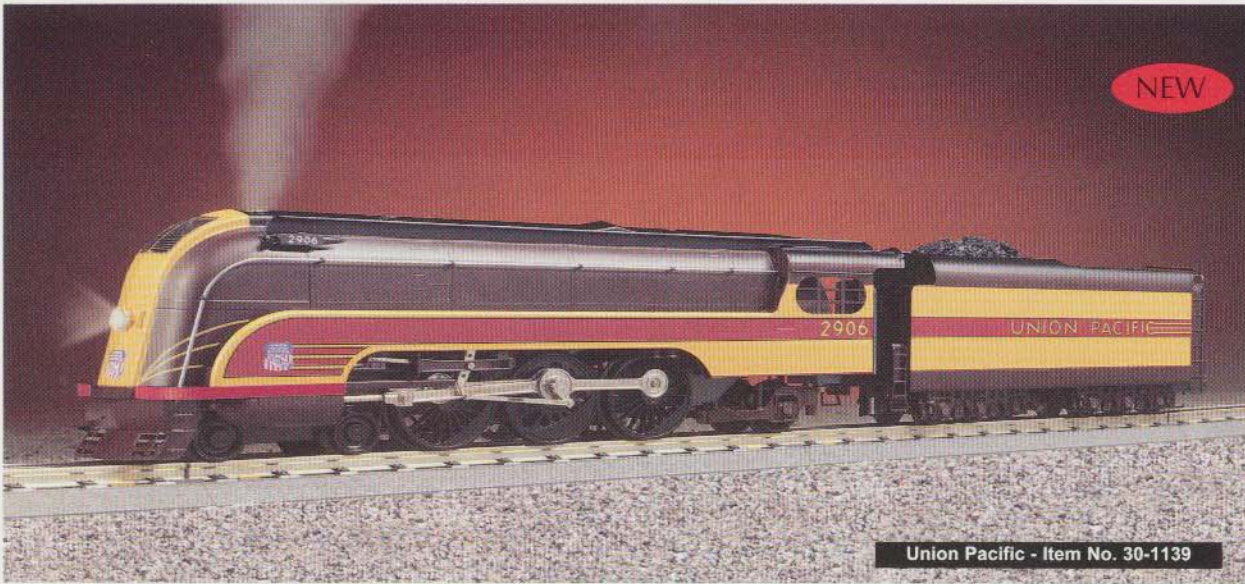

Optionally
Equipped
With

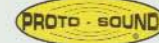

DESIGNED BY GEN

See Page 4 for Details



When most railfans think of Union Pacific streamliners, they picture the landmark M-10000 or EMD E-Units. What most people do not know is that U.P. took a stab at streamlined steam locomotives with the short-lived Forty-Niner from 1939-41. The 2906, equipped with roller bearings and lightweight rods, pulled the Forty-Niner at speeds over 90 miles per hour on the way to San Francisco.

MTH is proud to present the first traditionally sized Union Pacific Forty-Niner for your O-27 layout. The Forty-Niner now joins the Norfolk & Western J, Southern Pacific Gs-4 Daylight, New York Central Commodore Vanderbilt, Pennsylvania

Torpedo, and the New York Central Dreyfuss on the roster of RailKing streamlined steamers. The die-cast boiler and tender are decorated with the brown and yellow livery that made the locomotive famous. Underneath the die-cast skin lie the Forty-Niner's metal chassis, metal drivers and rods, metal coupler, and a precision flywheel equipped motor. The vision of the billowing ProtoSmoke® system will make any steam fan a little teary-eyed and when combined with the optional Proto-Sound® digital sound and train control system, the RailKing Forty-Niner is sure to be the pride of your locomotive roster.

4-6-2 FORTY-NINER LOCOMOTIVE FEATURES INCLUDE:

- Die-Cast Boiler and Tender
- Prototypical Metal Drivers
- Metal Handrails and Decorative Whistle
- Precision Flywheel Equipped Motor
- Operating Headlight
- Operates on O-27 Track
- Detailed Cab Interior
- DCRU® Reversing Unit
- Operating Metal Coupler
- Operating ProtoSmoke® System
- Optionally Equipped with Proto-Sound® Digital Sound and Train Control, Passenger Station Proto-Effects™ and Remote Controlled Proto-Coupler®
- Measures Approximately:
19 3/4" x 2 1/2" x 3 1/2"

Add A Matching Set of Cars, See Page 17



4-6-2 FORTY-NINER STEAMER



4-8-4 NORTHERN STEAMER



Optionally
Equipped
With



The heaviest straight passenger locomotives ever produced, the famous Santa Fe 4-8-4 Northern epitomized steam power. The steep graded western lines of the Santa Fe required a locomotive with enormous power and the Northern was the answer. The first Northern was delivered from Baldwin in 1927. By the 1940's, the new oil-burning 2900 series had arrived and were known as the largest 4-8-4's ever built. With their tremendous sixteen wheel tenders, these Northern measured over 120 feet long and were often rostered for the entire journey from Chicago to Los Angeles, a distance of over 1,700 miles!

MTH Electric Trains is proud to announce a RailKing version of the monster Santa Fe Northern. This beautiful O-27 steamer is outfitted with the

incredible MTH ProtoSmoke® system and can be optionally equipped with the Proto-Sound® digital sound system. Proto-Sound® equipped models feature squeaking brake sounds, freight yard sounds, an authentic whistle, and realistic chuffing and steam sounds. Operationally, the RailKing Northern will provide years of beautiful, smooth, quiet service. All Northern have precision flywheel equipped motors underneath a finely detailed die-cast metal boiler. The chassis and running gear are also produced entirely of metal-exemplifying the quality and detail that you have come to expect from RailKing locomotives.

4-8-4 NORTHERN STEAMER FEATURES INCLUDE:

- Die-Cast Boiler and Tender
- Boxpok Metal Drivers
- Metal Handrails and Decorative Whistle
- Precision Flywheel Equipped Motor
- Operating Headlight
- Operates on O-27 Track
- Detailed Cab Interior
- DCRU® Reversing Unit
- Operating Metal Coupler
- Operating ProtoSmoke® System
- Optionally Equipped with Proto-Sound® Digital Sound and Train Control, Freight Yard Proto-Effects™ and remote Controlled Proto-Coupler®
- Measures Approximately:
24" x 2 1/2" x 3 1/2"

4 - 8 - 4 NORTHERN STEAMER

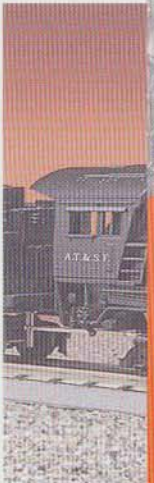

CHESSIE CONSTRUCTION SET

The popular Chessie Construction Set is back for 1998!

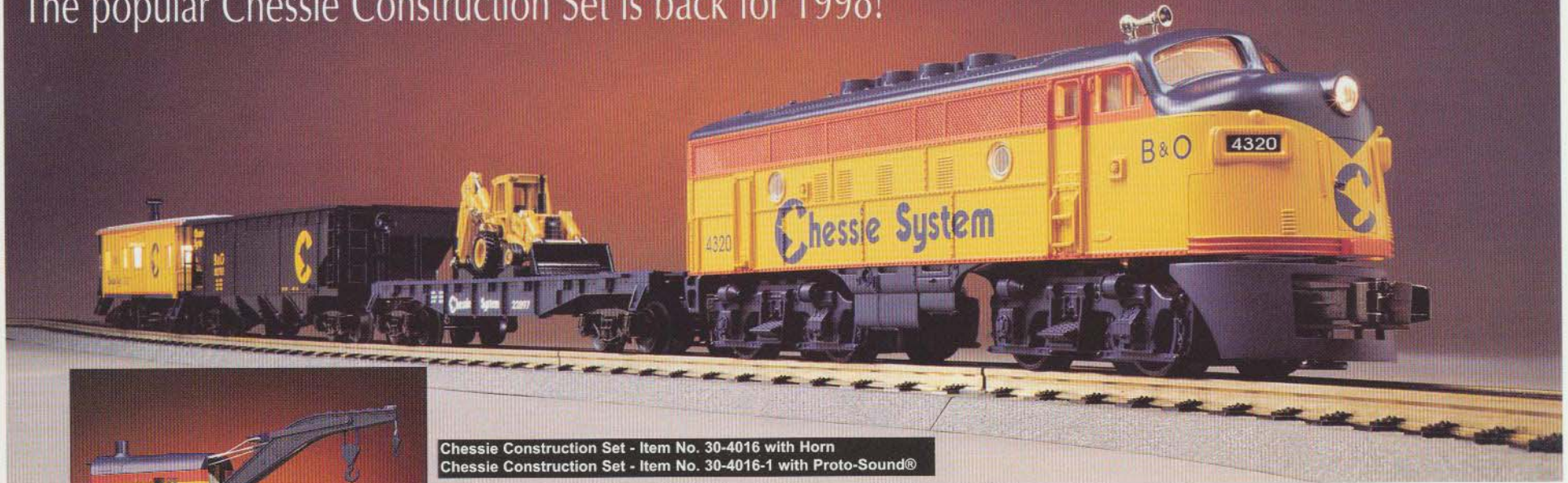

Chessie Construction Set - Item No. 30-4016 with Horn
Chessie Construction Set - Item No. 30-4016-1 with Proto-Sound®

Add a Crane Car to your Chessie Set. See page 20.

Optionally
Equipped
With



Railfans, an exciting, affordable train set is rolling out of the MTH shops this Fall just in time for the Holiday gift giving season! The Chessie Freight Special makes its return to the RailKing lineup this Season with all the sound, color and features that make RailKing ready-to-run sets the best value in model railroading today.

This complete set features a twin-motored Chessie F-3 diesel that can be purchased with either an electronic horn or the optional Proto-Sound® Digital Sound and Train Control system. In addition to the F-3, the set contains two sturdy RailKing freight cars

outfitted with die-cast metal trucks and operating couplers, an illuminated caboose with die-cast trucks and operating couplers, a 12-piece oval of MTH RiteTrax® track and a powerful 75-watt transformer.

The Chessie Freight Special sets up in minutes and easily expands with additional sections of MTH RiteTrax® track. Best of all, the 75-watt transformer is powerful enough to operate lighted accessories and additional rolling stock without surpassing its capacity. It's the perfect value-packed solution for starting your family's model railroading tradition.

ENGINE FEATURES INCLUDE:

- Die-Cast Truck Sides, Pilots
- Colorful Paint Schemes
- Operates on O-27 Track
- Decorative Metal Horn
- Optionally equipped with the Proto-Sound® Digital Sound and train Control System, Freight Yard Proto-Effects™ and Remote Controlled Proto-Coupler®
- 2 Precision Flywheel Equipped Motors

ROLLING STOCK FEATURES INCLUDE:

- Durable ABS Bodies
- Metal Trucks and Couplers

O-27 4-CAR PASSENGER SETS

O-27 MADISON PASSENGER SET



Pennsylvania - Item No. 30-6250

RailKing passenger cars are designed for years of operating fun with their sturdy construction, die-cast metal trucks and operating couplers, and tough ABS plastic bodies. They include detailed and illuminated car interiors and end-of-car diaphragms for even more realism. In addition, all RailKing passenger cars feature smooth rolling needle point axles for less drag and easy pulling.

O-27 4-CAR PASSENGER SET FEATURES INCLUDE:

- Die-Cast 4 or 6 Wheel Trucks
- Operating Metal Couplers
- Interior Detail in Passenger Cars
- Each Car Features 2 Overhead Lights
- End-of-Car Diaphragms
- Operates on O-27 Curves
- Undercarriage Detail
- Each Car Measures Approximately: 12 1/2" x 2 1/2" x 3 3/4"

O-27 STREAMLINED PASSENGER SET



Union Pacific - Item No. 30-6107

O-27 2-CAR PASSENGER SETS

Every Passenger Car Features Detailed Seat Interior and Overhead Lighting!

NEW



Amtrak - Item No. 30-6501

O-27 SUPERLINER SLEEPER/DINER SET



Add More Cars to your Amtrak Genesis Set

Amtrak Genesis Set - Item No. 30-4018

O-27 MADISON COMBINE/DINER SET



New York Central - Item No. 30-6257

O-27 STREAMLINED COMBINE/DINER SETS



Pennsylvania - Item No. 30-6106



Santa Fe - Item No. 30-6105

Expand your RailKing Madison or Streamlined Passenger Sets with these exciting two-car add-on sets for a longer, more realistic consist. Painted to exact MTH specifications, these add-on sets are designed to match your earlier run 4-car RailKing Madison or Streamlined Passenger sets and feature individual car names or numbers for a realistic, prototypical look.

RailKing passenger cars are designed for years of operating fun. Each car features sturdy MTH construction, die-cast metal trucks with operating metal couplers, and tough ABS plastic bodies.

The passenger cars feature overhead interior illumination; all cars feature undercarriage detail and end-of-car diaphragms. Additionally, each car's trucks sport fast-angle wheels and needle-point axles for smooth rolling performance.

SLEEPER/DINER AND COMBINE/DINER FEATURES INCLUDE:

- Die-Cast 4 or 6 Wheel Trucks
- Durable ABS Bodies
- Operating Metal Couplers
- Detailed Passenger Car Interiors
- Overhead Lighting in Passenger Cars
- End of Car Diaphragms
- Undercarriage Detail
- Combine/Diner Cars Measure Approx: 12 1/2" x 2 1/2" x 3 3/4"
- Sleeper/Diner Cars Measure Approx: 15" x 2 3/8" x 4"

0-27 PASSENGER COMBINE/DINER SETS



SEMI-SCALE ROLLING STOCK

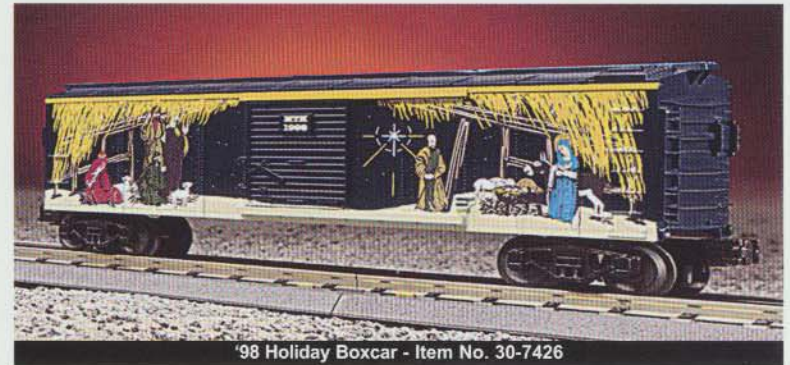

'98 HOLIDAY
BOX CAR

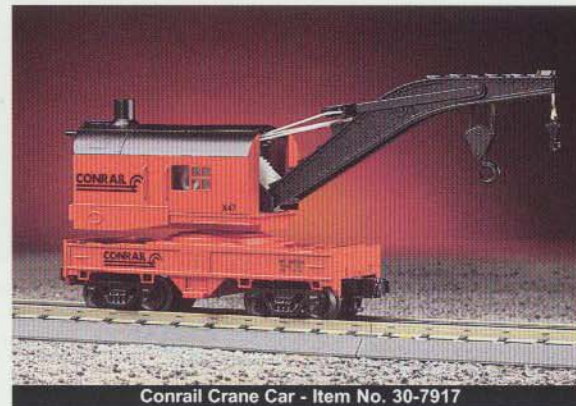

MANUAL OPERATING CRANE CARS

MANUAL OPERATING CRANE CAR FEATURES
INCLUDE:

- Moveable Hook
- Rotating Crane Body
- Operating Boom
- Die-Cast Sprung Trucks
- Operating Metal Couplers



Most RailKing freight cars feature fully sprung die-cast trucks with fast-angle wheels and needle point axles for a smooth rolling ride. Each truck has an operating metal coupler designed for years of use. RailKing cars are intricately molded in durable ABS plastic to last for years. All cars also feature underside detailing for that extra touch of realism.

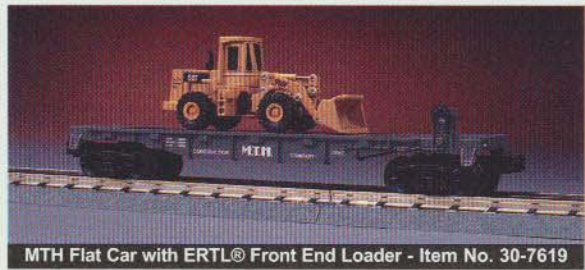
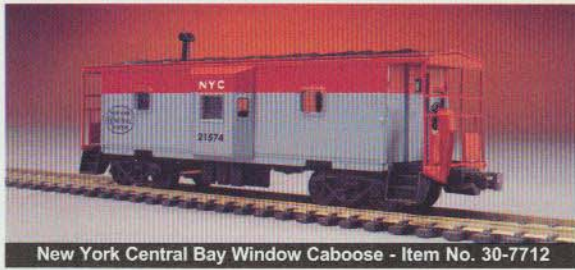

SEMI-SCALE FREIGHT CAR FEATURES INCLUDE:

- Durable ABS Intricately Detailed Bodies
- Die-Cast 4 Wheel Sprung Trucks
- Operating Metal Couplers
- Colorful Paint Schemes
- Most Cars Operate on O-27 Track
- Detailed Undercarriage
- Decorative Car Brake Wheels
- Fast Angle Wheel Sets
- Needle-Point Axles
- Sliding Boxcar and Stock Car Doors
- Stamped Metal Floors on Most Cars
- Each Car Measures Approximately: 10 1/2" x 2 1/2" x 3 3/4"

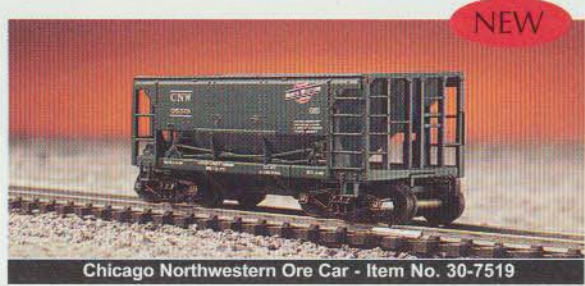

P R E M I E R

MTH ELECTRIC TRAINS

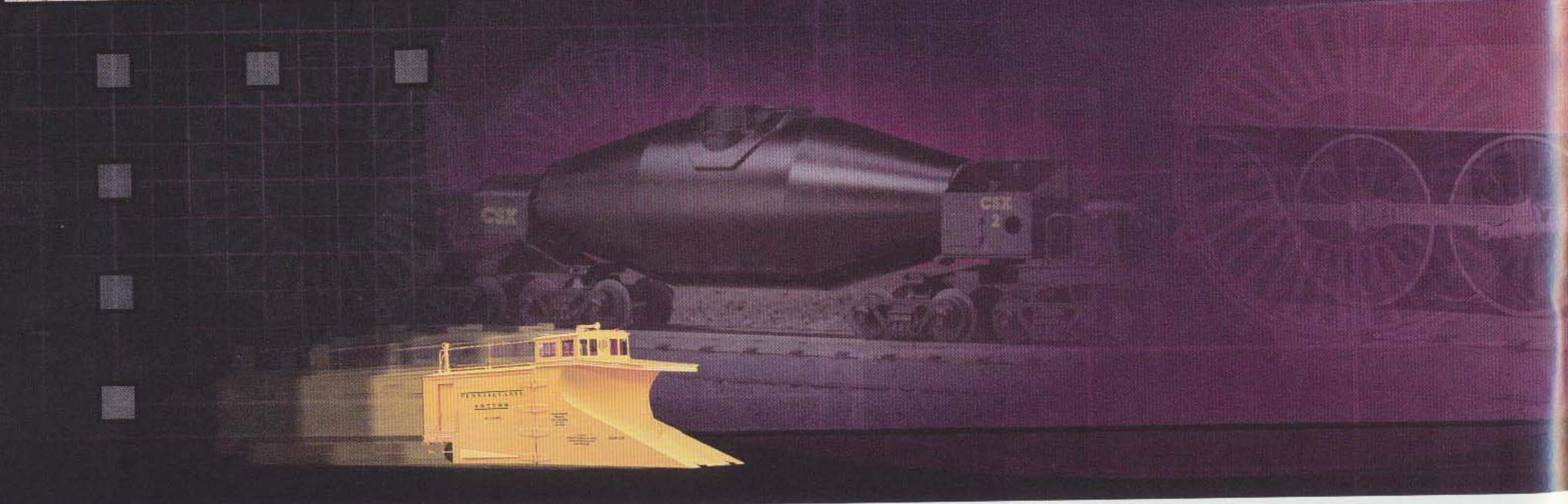



The MTH Premier Lineup has brought to O Gauge railroading some of the finest 1/4 inch scale models to ever grace an O Gauge pike. This tradition continues in 1998 with the release of several, never-before-offered locomotives and rolling stock items certain to appeal to even the most critical railfan.

Like all Premier Line steam locomotives, our 1998 models will feature die-cast boiler and tender construction, precision, flywheel-equipped power from Pittman® motors, voluminous smoke output from the exclusive ProtoSmoke® system, realistic digital sounds and effects from the Proto-Sound® Digital Sound and Train Control System and the raw power operators have come to expect in every Premier Line steam locomotive.

Our Premier Line diesel lineup features all new features and lower suggested retail pricing perfect for operators looking for well-detailed, attractively priced motive power. As with every Premier Line diesel unit, each power chassis features 2 flywheel-equipped motors guaranteed to provide years of smooth and quiet operation. All of our diesels also feature the Proto-Sound® Digital Sound and Train Control System which includes the easy-to-use remote uncoupling Proto-Coupler® system. And, in addition to Proto-Sound®, some of our '98 diesel offerings also include the remarkable ProtoSmoke® smoke unit system - guaranteed to provide the most diesel excitement in O Gauge railroading. Finally, most new diesel releases now feature stainless steel grill details, spinning roof fans, operating marker lights and lighted number boards. It all adds up to excitement that can only be found in MTH Premier Line diesel locomotives.

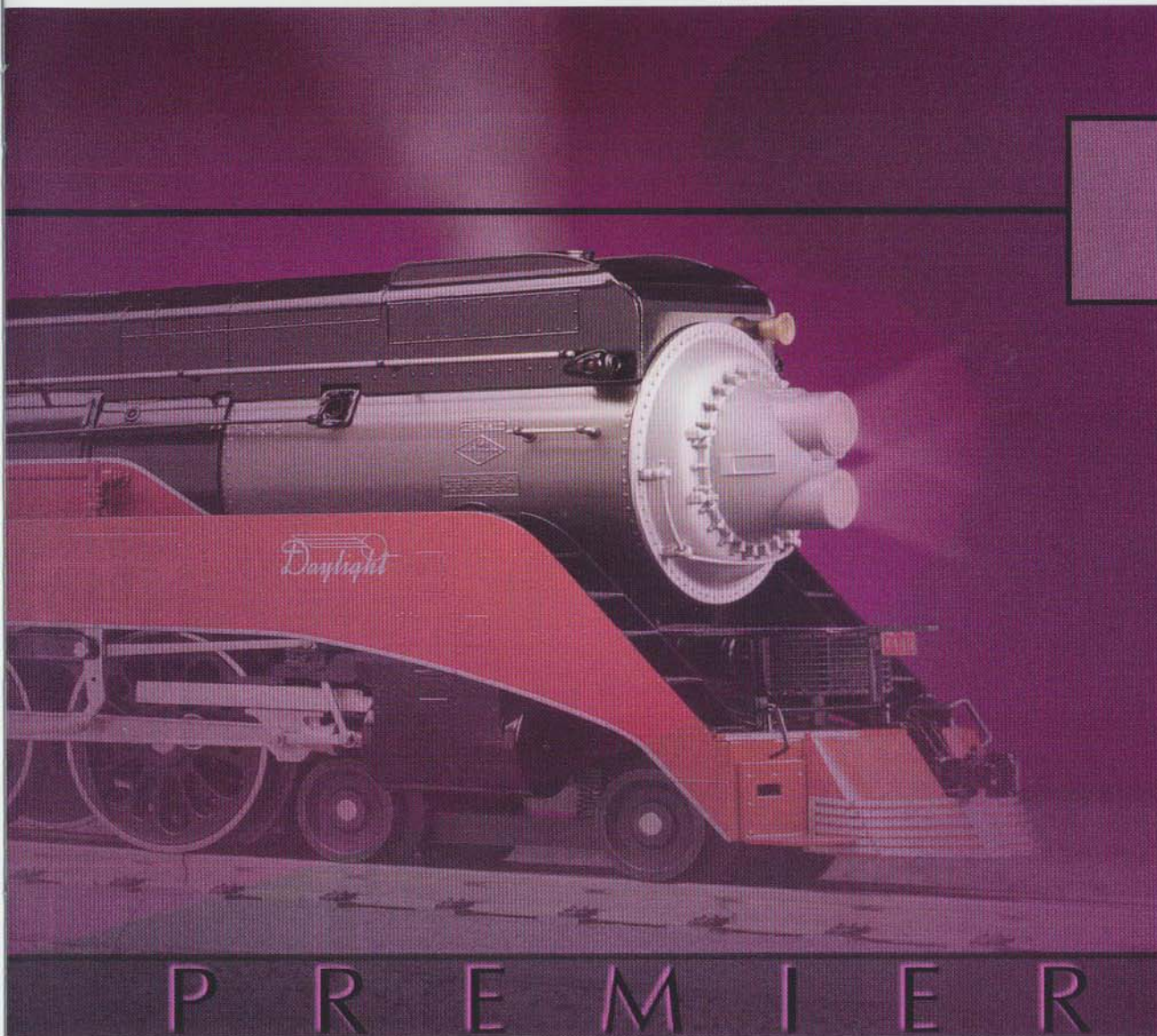



GP38-2 DIESEL

In the late 1960's, General Motors' EMD division responded to repeated complaints about the dependability of the GP30 and GP35 with the GP38. A descendant of the famous EMD F series, the GP38-2 became just as much a staple on railroads in its time as the F units were in theirs. While the GP38-2's prime mover produced less horsepower than its contemporaries, its excellent reputation made it one of the best selling Geeps ever. Almost every domestic railroad, big or small, has had its name painted on a GP-38. Many of these locomotives are still in use today in spite of the fact that the fleet is well past its twentieth anniversary.

By popular demand, the GP38-2 returns to the MTH Premier Lineup in today's most requested roadnames. Like our other Premier Line GP diesels, this 1:48 scale reproduction of the GP38-2 prototype features a durable, intricately detailed ABS body, die-cast trucks and trim, two precision flywheel-equipped motors, all new spinning roof fans, stainless steel grills, operating marker lights and lighted number boards as well as the exciting Proto-Sound® Digital Sound and Train Control System. This state-of-the-art system provides each engine with unique features not found on other 3-rail scale proportioned diesels, including constant voltage, directionally controlled lighting and remotely controlled operating Proto-Couplers®. Authentic diesel engine sounds, squeaking brakes, operating bell and horn sounds and unique freight yard sound effects round out the Proto-Sound® package.



Union Pacific - Item No. 20-2188

GP38-2 LOCOMOTIVE FEATURES INCLUDE:

- Durable ABS Diesel Body
- Metal Chassis
- Die-Cast Truck Sides, Pilots and Tanks
- Operates On O-31 Track
- Directionally Controlled Headlights
- 2 Precision Flywheel Equipped Motors
- Remote-Controlled Proto-Couplers®
- Stainless Steel Grills - **NEW**
- Operating Marker Lights - **NEW**
- Illuminated Number Boards - **NEW**
- Spinning Roof Fans - **NEW**
- Painted Handrails - **NEW**
- Lighted Cab Interior
- Engineer Cab Figure
- Metal Handrails and Horn
- Proto-Sound® Digital Sound and Train Control System Featuring Squeaking Brakes and Freight Yard Sound Effects
- Locomotive Measures Approximately: 18 1/2" x 2 5/8" x 3 7/8"

Equipped
With



DESIGNED BY OSIN

See Page 4 for Details



Chessie - Item No. 20-2186



S D - 9 0 M A C D I E S E L

General Motors' Electro Motive Division established its dominance on America's rails throughout railroading's modern era by consistently revolutionizing its motive power for today's ever-changing freight and passenger service needs.

The SD-90MAC exemplifies EMD's aggressiveness with its brand new H-Engine which delivers a whopping 6,000 horsepower and is so new that only a few engines have been delivered. The incredible horsepower rating and overall 80' engine length make the SD-90MAC the biggest and most powerful diesel locomotive on the rails today.

The MTH Premier Line SD-90MAC brings power and technology to your layout just as the real SD-90MAC's bring it to America's railroads. Each 1:48 scale SD-90MAC features two precision flywheel-equipped motors, a durable intricately detailed ABS body, die-cast trucks and trim, directional lighting, all-new spinning roof fans, lighted number boards and stainless steel grills as well as the incredible ProtoSmoke® smoke system and the Proto-Sound® Digital Sound and Train Control system. These and many other standard features found on MTH Premier Diesels are sure to make the MTH SD-90MAC a favorite for years to come.



Conrail SD-80 - Item No. 20-2190

SD-80/90MAC DIESEL LOCOMOTIVE FEATURES INCLUDE:

- Durable ABS Diesel Body
- Metal Chassis
- Die-Cast Truck Sides, Pilots and Fuel Tank
- Operates On O-42 Track
- Directionally Controlled Headlights
- Illuminated Number Boards - **NEW**
- 2 Precision Flywheel Equipped Motors
- Remote Controlled Proto-Couplers®
- Lighted Cab Interior
- Engineer Cab Figure
- Painted Handrails - **NEW**
- Operating ProtoSmoke® System
- Spinning Roof Fans - **NEW**
- Metal Handrails and Decorative Roof Horn
- Proto-Sound® Digital Sound and Train Control Featuring Squeaking Brakes and Freight Yard Sound Effects
- Stainless Steel Grills - **NEW**
- Locomotive Measures Approximately: 20" x 2 1/2" x 3 3/4"

Equipped With

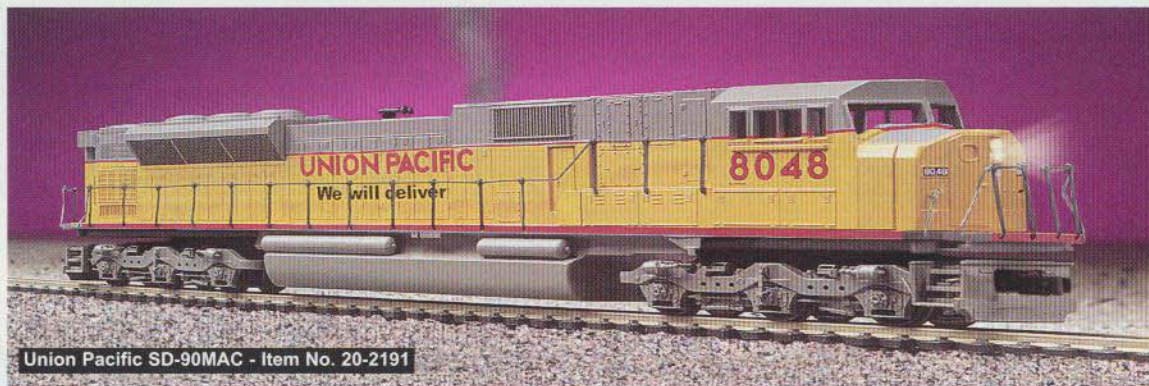

Union Pacific SD-90MAC - Item No. 20-2191





4 - 8 - 4 G s - 4 S T E A M E R



Southern Pacific - Item No. 20-3029

Equipped With

PROTO-SOUND
DESIGNED BY CSTN
See Page 4 for Details

Proto-Coupler
ON BOARD

ProtoSMOKE
EQUIPPED

Southern Pacific's Gs-4 Daylight was one of the most beautiful and technologically advanced locomotives ever produced. Built in the early 1940's, the Gs-4's employed an advanced train braking system that made high speed travel safer by utilizing the use of water spray onto the locomotive drivers to cool them on long downgrades. Technological advancement alone was not enough to capture the hearts of railfans though. What most people found appealing about the Gs-4 Daylights were the vivid black, silver and orange paint scheme found on its graceful streamlined skin.

The MTH Premier Line Gs-4 captures all the beauty, power, and technological advancement of the original. The 8 boxpok drivers deliver the pulling power you have come to expect from MTH loco-

motives and the authentic paint scheme truly captures the beauty of the original. Our high tech design and tooling capabilities ensure that all seams and rivets are crisp and accurate to a degree not attainable by other die cast manufacturers. The legendary ProtoSmoke® system puts out so much smoke, you will swear you are watching your Gs-4 working hard to pull the Daylight up the Santa Margarita Hill on its way to the San Fernando Valley.

Inside each body you will find a precision fly-wheel-equipped Pittman® motor and the exciting Proto-Sound® digital sound and train control system. Realistic chuffing and steam sounds along with a powerful whistle and Passenger Station sound effects make the experience of running the Gs-4 even more memorable.

4-8-4 Gs-4 STEAM LOCOMOTIVE FEATURES INCLUDE:

- Constant Voltage Headlight
- Operating Mars Light
- Die-Cast Trucks
- Precision Pittman® Motor with Flywheel Drivetrain
- Remote Controlled Proto-Coupler®
- 2 or 3-Rail Versions
- Metal Handrails and Decorative Whistle
- Proto-Sound® Digital Sound and Train Control System with Squeaking Brakes and Passenger Station Proto-Effects™
- Die-Cast Boiler and Tender Bodies
- Lighted Cab Interior
- Cab Engineer and Fireman Figures
- Operating ProtoSmoke® System
- Operates on O-54 Curves
- Measures Approximately:
26 1/2" x 2 1/2" x 4"

Add a Matching Set of Cars , See Page 32



SCALE GENESIS DIESEL



SCALE SUPERLINER SETS

NEW



Amtrak Genesis- Item No. 20-2189

By the late 1980's, Amtrak was searching for a replacement for its outdated and aging fleet of F40PH and GP-40's. Weary of getting more locomotives that were really designed for freight operation, Amtrak searched for a new, lightweight, high-tech alternative. General Electric provided Amtrak with an answer with its unveiling of the "Genesis." Featuring a monocoque frame, advanced electronics, and special environmental and safety features, the Genesis represents the state-of-the-art in U.S. passenger service.

For 1998, the MTH Premier Line Genesis brings you everything you have come to expect from MTH diesels. Like our other Premier Line diesel engines, this 1:48 scale reproduction of the Genesis

prototype features a durable, intricately detailed ABS body, die-cast trucks and trim, two precision flywheel-equipped motors, and the exciting Proto-Sound® Digital Sound and Train Control System. This state-of-the-art system provides each engine with unique features not found on other 3-rail scale proportioned diesels, including constant voltage, directionally controlled lighting and remotely controlled operating Proto-Couplers®. Authentic diesel engine sounds, squeaking brakes, operating bell and horn sounds and unique passenger station announcements round out the Proto-Sound® package. Coupled with double-decker Superliner passenger cars (see below), the Genesis heads up a great looking consist.

GENESIS LOCOMOTIVE FEATURES INCLUDE:

- Durable ABS Diesel Body
- Metal Chassis
- Die-Cast Truck Sides, Pilots and Tanks
- Operates On O-31 Track
- Directionally Controlled Headlights
- Illuminated Number Boards - **NEW**
- 2 Precision Flywheel-Equipped Motors
- Remote-Controlled Proto-Couplers®
- Lighted Cab Interior
- Engineer Cab Figure
- Operating ProtoSmoke® System
- Spinning Roof Fans - **NEW**
- Metal Grab Rails and horn
- Proto-Sound® Digital Sound and Train Control System Featuring Squeaking Brakes, Passenger Station Proto-Effects™ and Remote Controlled Proto-Couplers®
- Stainless Steel Grills - **NEW**
- Locomotive Measures Approximately: 18 1/2" x 2 1/2" x 3 3/4"

Equipped With





See Page 4 for Details

Add A Matching Set of Cars

NEW



4-Car Scale Superliner Set- Item No. 20-6524

4-CAR SUPERLINER FEATURES INCLUDE:

- Die-Cast Trucks
- Operating Metal Couplers
- Interior Detail
- Overhead Lighting
- Operates on O-42 Curves
- Undercarriage Detail
- Each Car Measures Approximately: 18 1/2" x 2 3/8" x 4"

PREMIER

GENESIS DIESEL SUPERLINER SETS

PAGE 31



70' SCALE PASSENGER SETS

Every Passenger Car Features Detailed Seat Interior and Overhead Lighting!



5-CAR 70' SCALE STREAMLINED PASSENGER SET

It is hard to match the fun and beauty of a long, sleek, passenger train speeding down the rails. Regardless of the roadnames, colorful matching passenger cars and locomotives are what make running passenger trains so much fun. Add exceptional interior and exterior detail at a great price, and there is no end to the hours of enjoyment you will have.

For 1998, MTH brings another new paint scheme to the Premier line passenger car roster. These new smooth-sided

Southern Pacific Daylight cars offer unsurpassed detail, beauty, and value to the O Gauge railroader. Each five car set features beautifully decorated passenger cars with undercarriage detail, interior seating, overhead lighting, and rubber end-of-car diaphragms. Each car's detailed and durable ABS body sits atop die-cast metal trucks with operating metal couplers.

5-CAR 70' PASSENGER SET FEATURES INCLUDE:

- Die-Cast Trucks
- Operating Metal Couplers
- Interior Detail in Passenger Cars
- Each Passenger Car Features Overhead Lights
- Operates on O-42 Curves
- All **NEW** Body Design
- Undercarriage Detail
- Each 5-Car Set Features 1 Baggage, 1 Observation, 2 Coaches and either 1 Vista Dome or 3 Coaches
- Each Car Measures Approximately:
18 3/4" x 2 1/2" x 3 1/2"

2-CAR 70' SCALE SLEEPER/DINER PASSENGER SETS

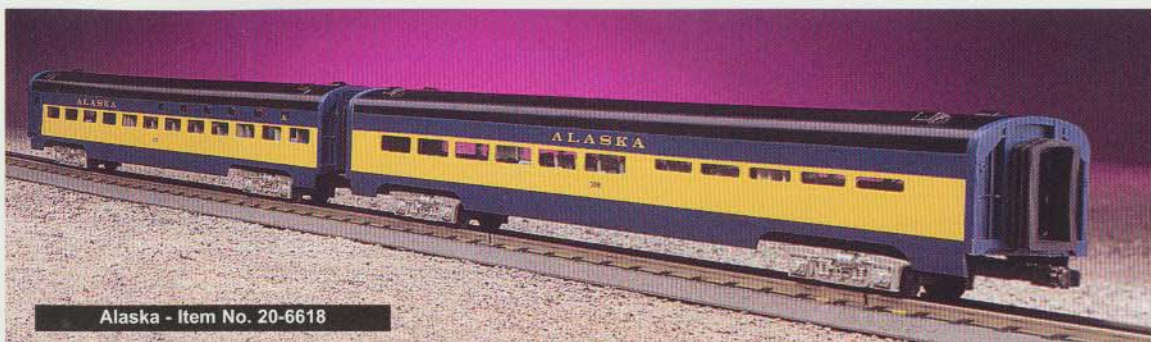

Alaska - Item No. 20-6618



New York Central - Item No. 20-6616



Southern - Item No. 20-6617



Southern Pacific - Item No. 20-6623

Expand your Premier Streamlined Passenger Sets with these exciting two car add-on sets for longer, more realistic consists. These cars feature prototypical names and numbers and are decorated to match our earlier 5-car sets.

Each car features a highly detailed ABS body that rides on a detailed chassis with metal trucks and couplers. Like their matching 5-car set brethren, these cars are equipped with detailed interiors, overhead lighting, and end-of-car diaphragms.

2-CAR 70' PASSENGER CAR FEATURES INCLUDE:

- Die-Cast 4 Wheel Trucks
- Operating Metal Couplers
- Interior Detail in Passenger Cars
- (2) 3rd-Rail Pickups per Car
- Each Passenger Car Features Overhead Lights
- Operates on O-42 Curves
- **All NEW** Body Design
- Undercarriage Detail
- Each Car Measures Approximately: 18 3/4" x 2 1/2" x 3 1/2"

O - S C A L E R O L L I N G

NEW

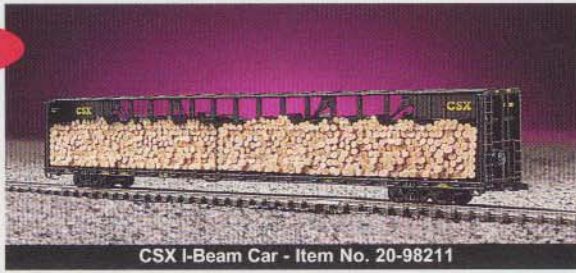

CSX I-Beam Car - Item No. 20-98211

NEW

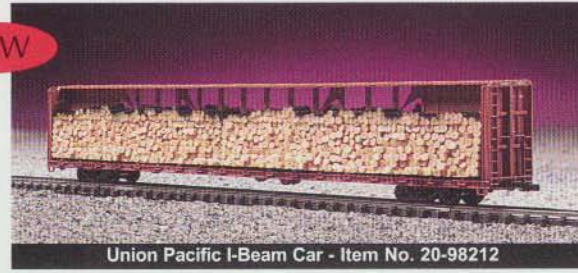

Union Pacific I-Beam Car - Item No. 20-98212

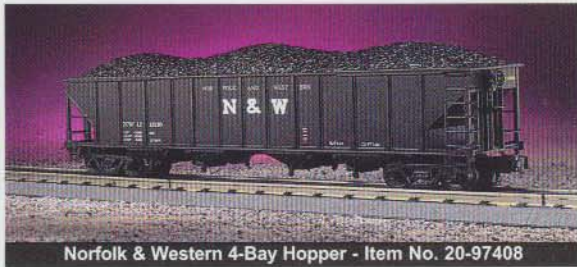

Norfolk & Western 4-Bay Hopper - Item No. 20-97408

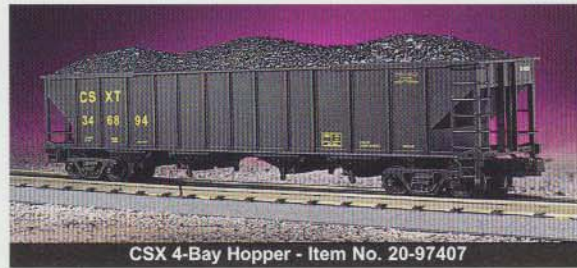

CSX 4-Bay Hopper - Item No. 20-97407

NEW



Chicago Northwestern Scale Length Gondola - Item No. 20-98005

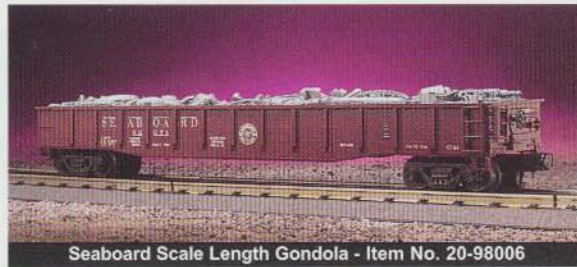

Seaboard Scale Length Gondola - Item No. 20-98006

NEW

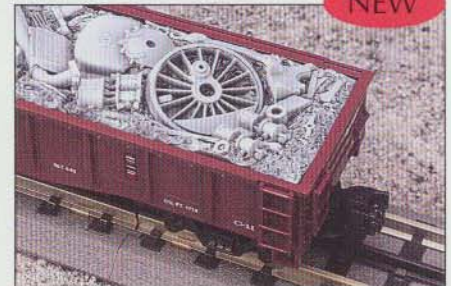

All
Hoppers
and
Gondolas
come with
Realistic
Coal Loads
or
Junk Loads

"Drop a load" in your previously purchased Hopper or Gondola cars , See Page 46

STOCK



Seaboard Tank Car - Item No. 20-96009

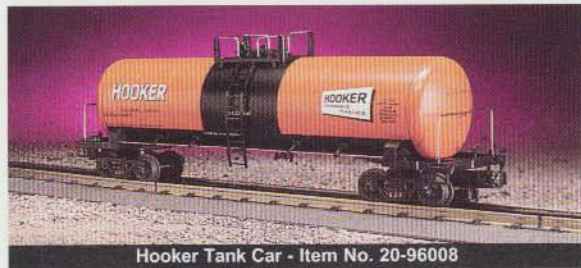

Hooker Tank Car - Item No. 20-96008

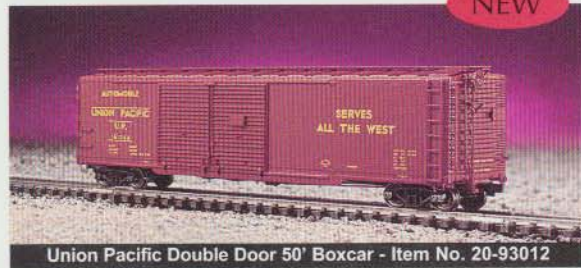

Union Pacific Double Door 50' Boxcar - Item No. 20-93012

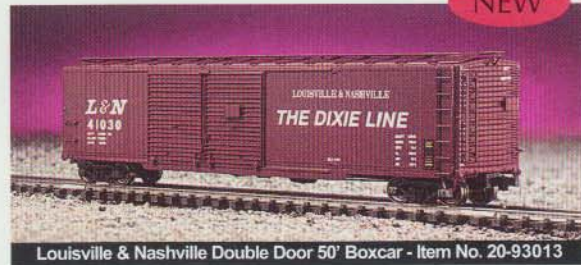

Louisville & Nashville Double Door 50' Boxcar - Item No. 20-93013

All our Premier Line freight cars have ABS plastic bodies mounted atop die-cast, sprung (excluding cabooses) trucks with operating metal couplers. The intricately detailed bodies and smooth rolling trucks are bound to make these MTH Scale Freights your favorites.

O SCALE FREIGHT CARS FEATURES INCLUDE:

- Durable ABS Intricately Detailed Bodies
- Die-Cast 4 Wheel Trucks
- Operating Die-Cast Couplers
- Colorful Paint Schemes
- Most Cars Operate on O-31 Track
- Decorative Brake Wheels
- Fast Angle Wheel Sets
- Needle-Point Axles
- Sliding Car Doors
- Stamped Metal Floors on most Cars
- 1/4 Inch Scale Dimensions

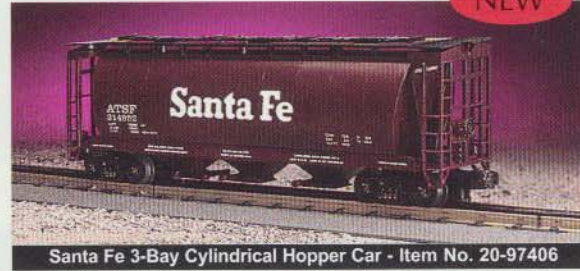

Santa Fe 3-Bay Cylindrical Hopper Car - Item No. 20-97406

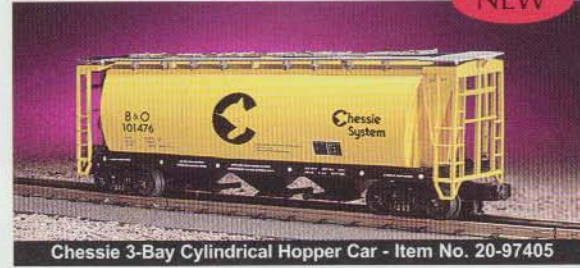

Chessie 3-Bay Cylindrical Hopper Car - Item No. 20-97405



CCA Boxcar - Item No. 20-93011

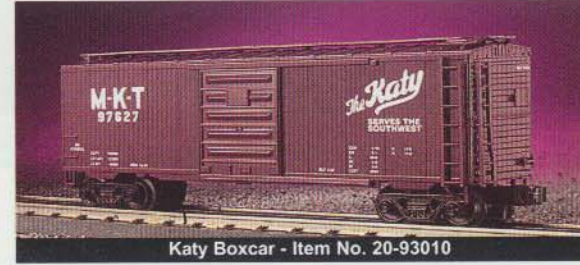

Katy Boxcar - Item No. 20-93010

O SCALE ROLLING STOCK

PREMIER

PAGE 35

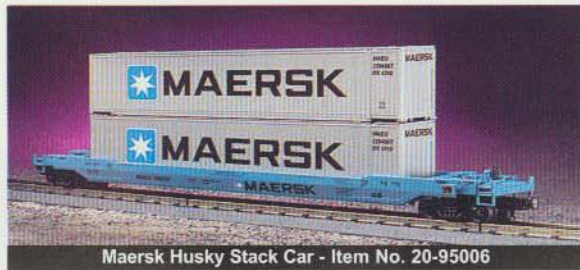

Maersk Husky Stack Car - Item No. 20-95006

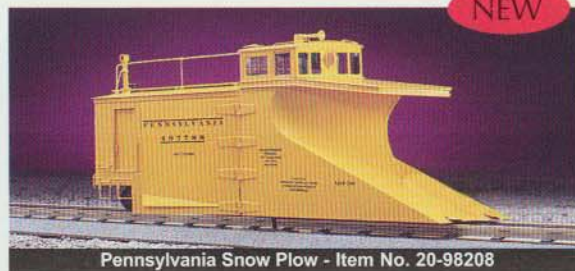

Pennsylvania Snow Plow - Item No. 20-98208

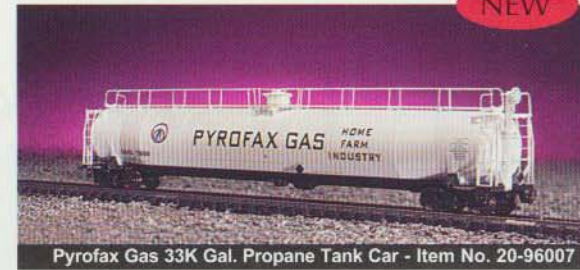

Pyrofax Gas 33K Gal. Propane Tank Car - Item No. 20-96007



Union Pacific Husky Stack Car - Item No. 20-95007



Union Pacific Snow Plow - Item No. 20-98207



Suburban Propane 33K Gal. Propane Tank Car - Item No. 20-96006



Amtrak Reefer Car - Item No. 20-94010

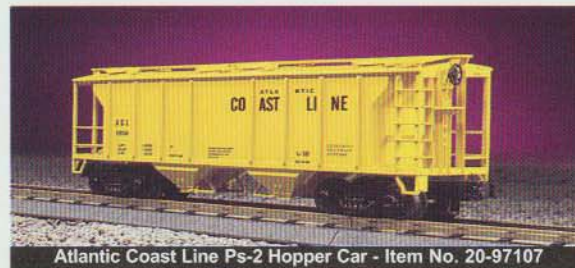

Atlantic Coast Line Ps-2 Hopper Car - Item No. 20-97107



CSX Hot Metal Car - Item No. 20-98209



Chesapeake & Ohio Reefer Car - Item No. 20-94011

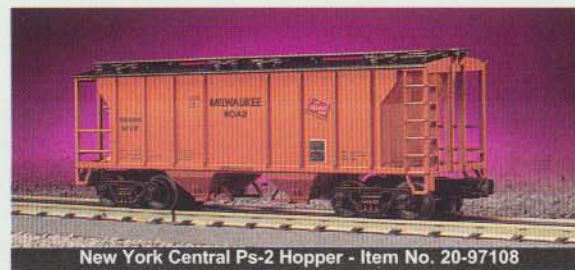

New York Central Ps-2 Hopper - Item No. 20-97108



Pennsylvania Hot Metal Car - Item No. 20-98210



Z-4000™



Operators of any Proto-Sound® equipped locomotives will appreciate full sound control compatibility with the Z-4000™. The transformer's control panel has a voltage display, amperage display, and horn, bell, direction, and programming buttons for each track. Programming Proto-Sound® involves scrolling through the features on the LED display by using the whistle and direction buttons. Additional operating features are now possible thanks to the Z-4000™'s microprocessor control system.

Perhaps the most exciting feature of the Z-4000™ is its microprocessor-controlled operating system. There is actually a powerful home-computer-type "brain" that makes the Z-4000™ highly upgradeable. In fact, the Z-4000™ has been designed so that future add-ons like a walk-around throttle system will be easy and quick to install and use. This product has earned the UL Listing Mark.

Z-4000™ FEATURES INCLUDE:

- UL Listed to U.S. and Canadian Safety Standards
- Pure Sine Wave Power Signal
- (2) 21v Variable Track Outputs
- (1) 14v Fixed-Voltage Output
- (1) 10v Fixed-Voltage Output
- Internal Cooling Fan
- On/Off Power Switch
- Power and Overload Indicator Lights
- Expansion Port for Future Upgrades
- Compatible as Power Source for All O Gauge AC-Powered Locomotives
- Circuit Breakers for Each Output
- Large Red LED Overload Indicator
- Large Green LED Power On
- Measures 8 3/4" High, 11 1/8" Front to Back, 14 3/4" Wide



TINPLATE TRADITIONS™

MTH ELECTRIC TRAINS

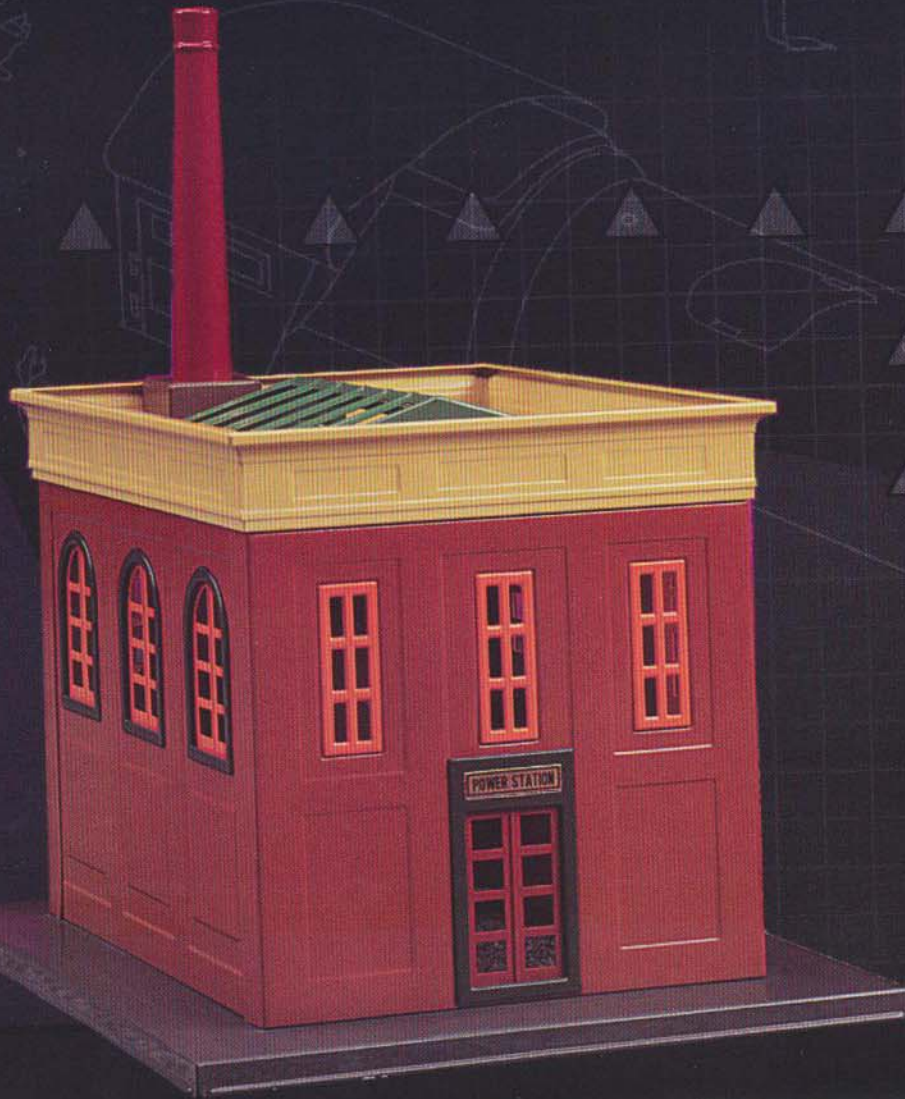



TINPLATE TRADITIONS

By MTH Electric Trains

At MTH, we haven't forgotten where model railroading got its start. That's why we have always been proud of our tinsplate productions over the years and why we are determined not to forget model railroading's heritage. For without tinsplate, the toy train hobby would surely lack some of its attractive appeal.

As we unveil our latest Tinsplate Traditions over the next few pages, we hope that you will take the time to marvel not only at our own recreations - including the often requested 200 Series Operating Crane Car - but at the impact those early toy trains had on today's manufacturers.

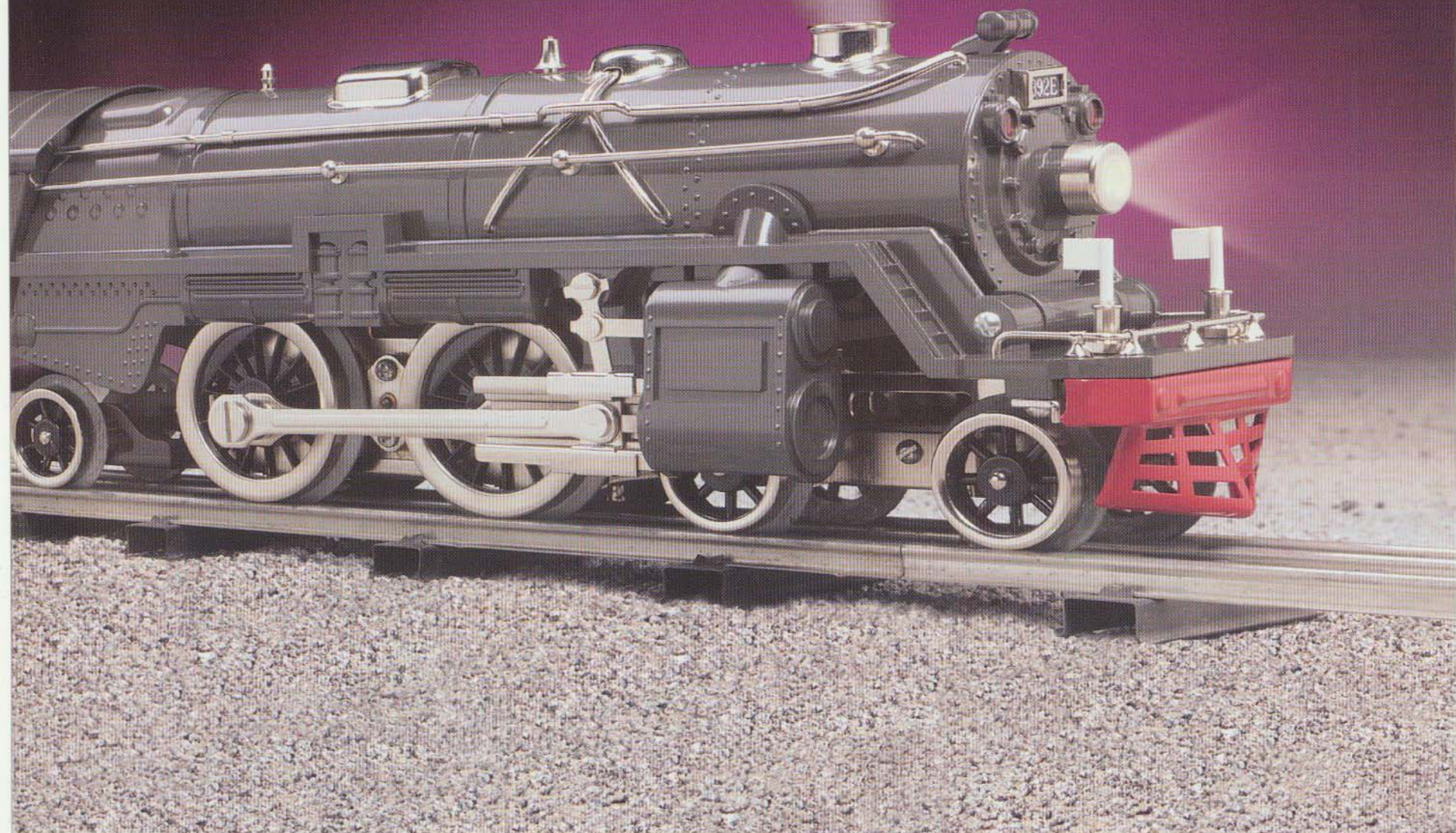

392E STEAM ENGINE & TENDER

With the exception of the venerable 400E, standard gauge's largest steam locomotive is the mammoth 392E. First produced in 1932, the 392E roars to life again as part of the MTH Tinplate Traditions line.

Evoking memories of yesteryear while (optionally) using the technology of today, the MTH 392E is available in two popular color versions: black with brass trim and gray with nickel trim. Operators will appreciate the option of purchasing their 392E equipped with a precision motor, ProtoSmoke®, and the Proto-Sound® digital sound and control system for a thoroughly modern operating experience in vintage tinplate tradition. Yet, traditionalists may prefer the option of a traditional mechanical reversing unit, mechanical whistle and Bild-A-LoCo motor system. Regardless of your preferences, every tinplate enthusiast can get exactly what they want under the hood of their locomotives.

Like all MTH Tinplate Traditions pieces, the 392E closely models the original of yesteryear. The boiler, tender, and running gear are made entirely of stamped metal. All painted surfaces are decorated with the traditional baked enamel. A sure favorite, the beautiful and durable 392E will pull your 200 series or 500 series cars for years to come.



Black w/Brass Trim - Item No. 10-1092

**392E STEAM ENGINE & TENDER
FEATURES INCLUDE**

- Baked Enamel Finish
- Stamped Metal Body
- Operating Metal Coupler
- Operating Headlight
- Metal Wheels and Axles
- Die-Cast Frame
- Measures Approximately:
27 1/2" x 5 3/4" x 4 1/2"

Choose from Two Models:

TRADITIONAL: Bild-A-LoCo Motor, Mechanical E-Unit and Mechanical Whistle

CONTEMPORARY: Pittman® Precision Motor, ProtoSmoke® and Proto-Sound® Digital Sound and Train Control with Freight Yard Proto-Effects™

Optionally
Equipped
With



Gray w/Nickel Trim - Item No. 10-1091

500 SERIES STD. GAUGE FREIGHT

MTH is proud to introduce a new generation of standard gauge lovers to the classic looks of the 500 series freight car. While slightly smaller than 200 series cars, the 500's carry the same beauty and level of trim detail. Like their 200 series brethren, the 500 series cars are constructed entirely of stamped metal components. Each car features black oxide finished trucks, metal truck jour-

nal boxes and sprung latch couplers for that authentic look and feel of yesteryear. Equally at home behind the MTH 392E or any other large standard gauge locomotive, these stunningly attractive freight cars add color and variety to any standard gauge layout or Christmas Garden.

500 SERIES STD. GAUGE BOX CAR - Measures: 13 1/4" x 3 1/2" x 4 7/8"



500 Series Std. Gauge Box Car - Item No. 10-1085
Yellow and Brown w/Nickel



500 Series Std. Gauge Box Car - Item No. 10-1086
Cream and Orange w/Brass

500 SERIES STD. GAUGE REEFER CAR - Measures: 13 1/4" x 3 1/2" x 4 7/8"



500 Series Std. Gauge Reefer Car - Item No. 10-1089
White and Blue w/Nickel Trim

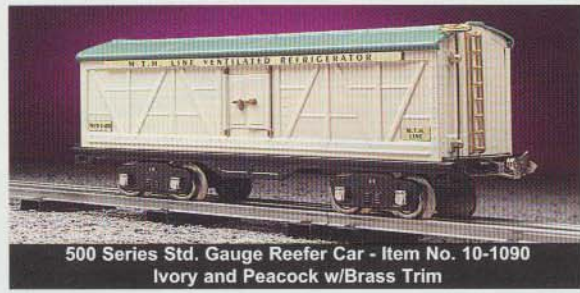

500 Series Std. Gauge Reefer Car - Item No. 10-1090
Ivory and Peacock w/Brass Trim

500 SERIES STD. GAUGE CATTLE CAR - Measures: 13 1/4" x 3 1/2" x 4 7/8"

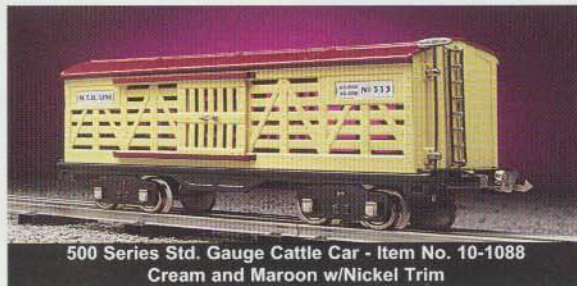

500 Series Std. Gauge Cattle Car - Item No. 10-1088
Cream and Maroon w/Nickel Trim

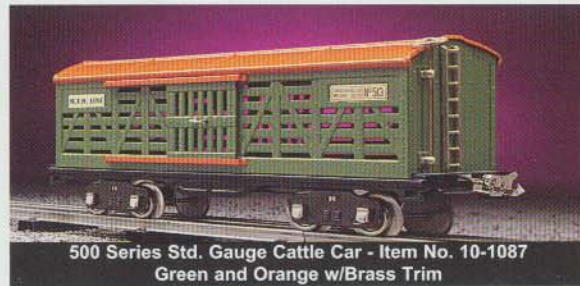

500 Series Std. Gauge Cattle Car - Item No. 10-1087
Green and Orange w/Brass Trim

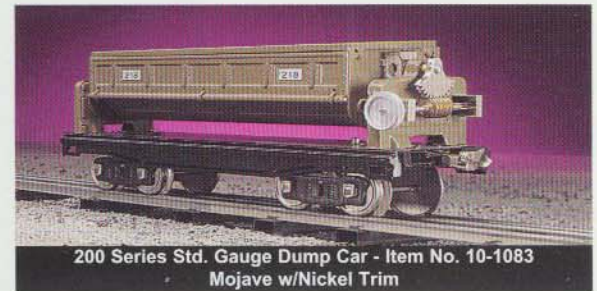

200 Series Std. Gauge Dump Car - Item No. 10-1083
Mojave w/Nickel Trim

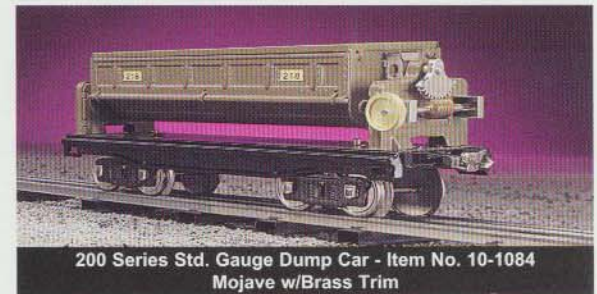

200 Series Std. Gauge Dump Car - Item No. 10-1084
Mojave w/Brass Trim

200 SERIES STD. GAUGE FREIGHT CARS

Each Car Measures: 14 1/2" x 4 3/4" x 4"

Add to your growing 200 series collection with the latest 200 series reproductions from MTH Tinplate Traditions™. 200 series cars are constructed entirely of stamped metal components. Each car features black oxide finished trucks, metal truck journal boxes and sprung latch couplers for that authentic look and feel of yesteryear. Equally at home behind the MTH 392E, 400E, 381E, 408E or any other large standard gauge locomotive, these stunningly attractive freight cars add color and variety to any standard gauge layout or Christmas Garden.



200 Series Std. Gauge Crane - Item No. 10-1081
Yellow w/Nickel Trim

200 SERIES CRANE CARS

Car Dimension: 21 3/4" x 6 1/4" x 4"



200 Series Std. Gauge Crane - Item No. 10-1082
Peacock w/Brass Trim

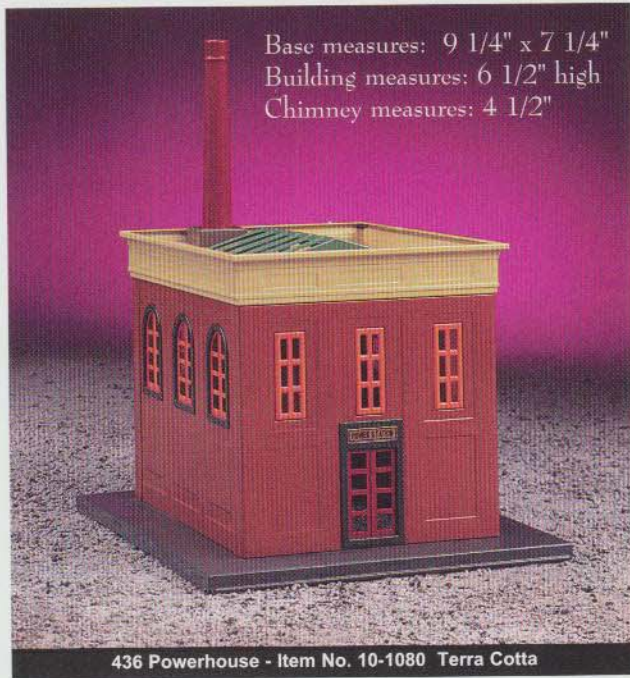

Base measures: 9 1/4" x 7 1/4"
Building measures: 6 1/2" high
Chimney measures: 4 1/2"

436 Powerhouse - Item No. 10-1080 Terra Cotta

436 POWERHOUSE

The Tinplate Traditions 436 Powerhouse faithfully reproduces the colors and construction of the original. Made entirely of stamped metal and decorated with a durable baked enamel finish, the 436 Powerhouse will compliment any tinplate layout.

STD. GAUGE TRACK

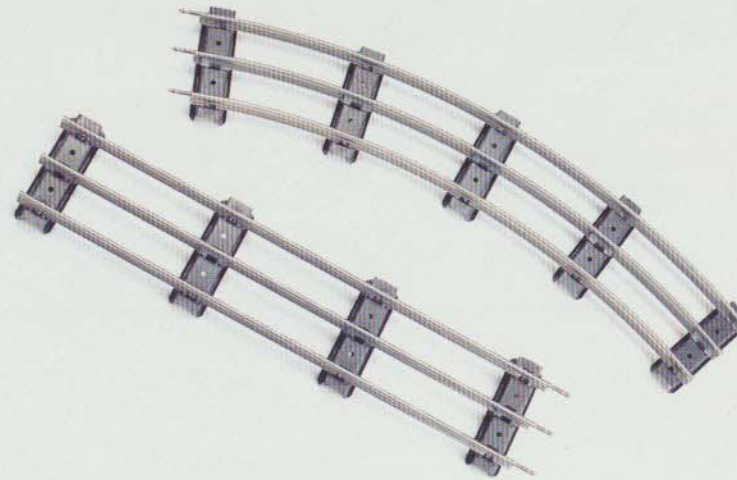

Regular Straight Section
Measures 14 1/2"

Item No. 10-1038

Extra Tie Straight Section
Measures 14 1/2"

Item No. 10-1040

Regular Curved Section

Item No. 10-1039

Wide Radius Curved Section

Item No. 10-1041

A C C E S S O R I E S

MTH ELECTRIC TRAINS

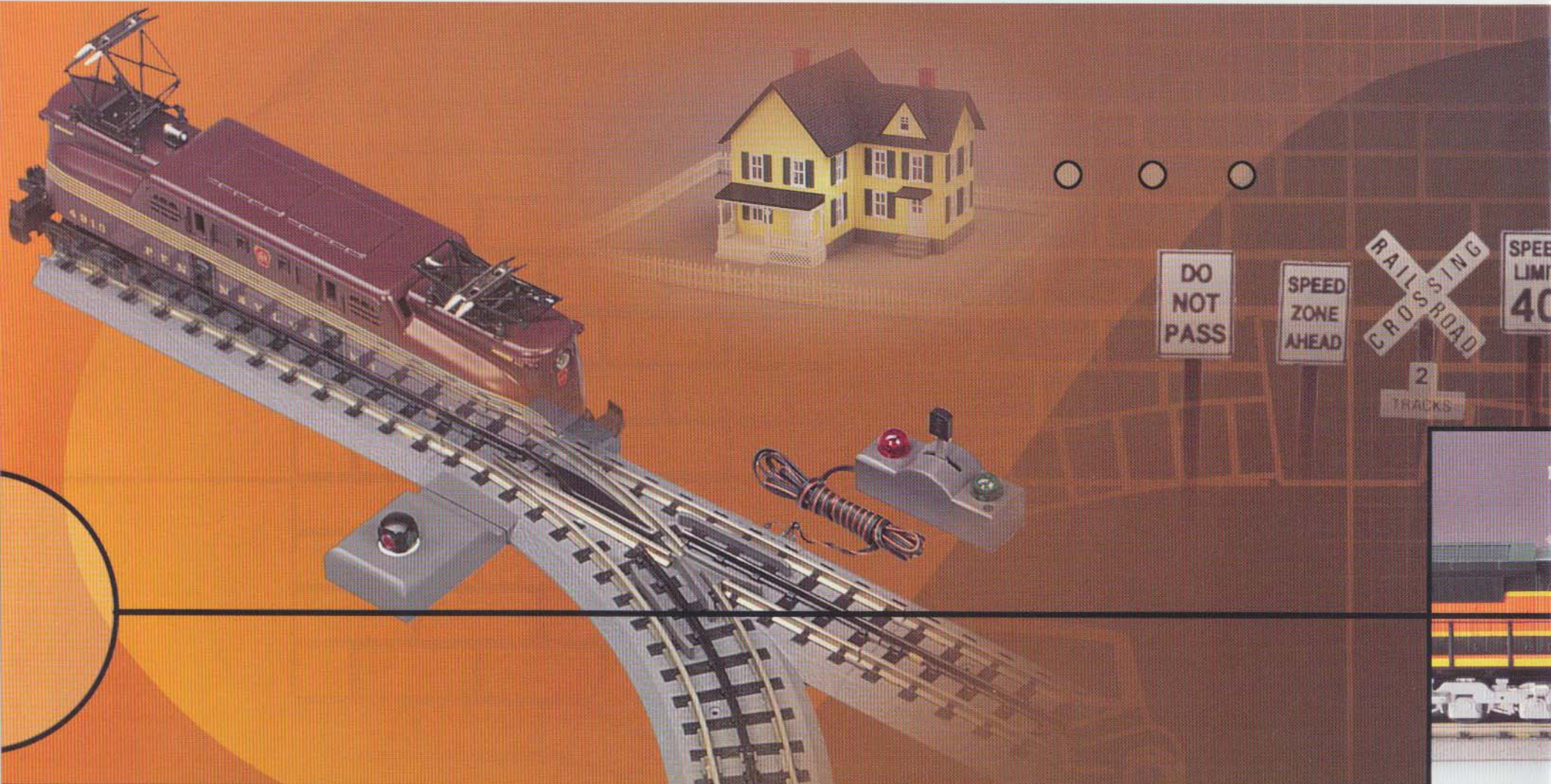

A C C E S S O R I E S

#8-4-NORRIS-STEAMER

RAIL KING
By MTH Electric Trains

Great accessories have been a part of the RailKing® line since its inception and we intend to continue that tradition in 1998. Model railroaders can choose from several exciting new operating accessories as well as some past RailKing® favorites.

We've expanded our MTH RiteTrax® System in 1998 with O Gauge railroading's best operating O Gauge switch. Featuring the look and style of MTH RiteTrax's® easy-to-assemble design, our new MTH RiteTrax® switches are an operators best switch choice. Best of all, thanks to our new MTH RiteTrax® adapter track section, MTH RiteTrax® switches can be used with any major track system.

In addition to MTH RiteTrax®, you'll find an incredible selection of die-cast metal lamp sets in both traditional and O Scale proportions. There is also a fun selection of RailTown™ buildings to choose from, each fully painted, assembled and decorated for out-of-the-box use!



JUNK LOAD

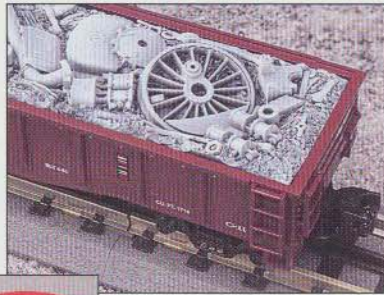

NEW

Realistic coal loads
available for all
RailKing® and Premier
Hoppers

Junk Load - Item No. 30-50003 (RailKing)
Junk Load - Item No. 20-30001 (Premier)

COAL LOAD

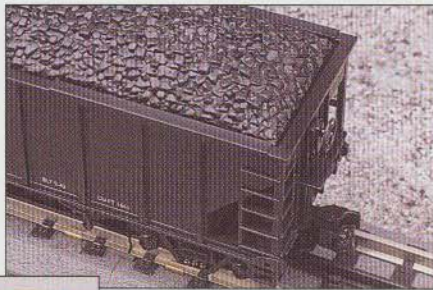

NEW

Realistic junk loads
available for all
RailKing® and Premier
Gondolas

Coal Load - Item No. 30-50001 (RailKing)
Coal Load - Item No. 20-30002 (Premier)

COMES COMPLETELY
ASSEMBLED

PASSENGER STATION



Passenger Station - Maroon & Grey - Item No. 30-9014

Passenger Station Measures: 19" x 9" x 8 1/2"

ILLUMINATED
INTERIOR

PASSENGER STATION PLATFORM

A new RailTown™ building joins your layout in a big way. The Passenger Station is a two-story building with two passenger platforms. Like other RailTown™ buildings, the Passenger Station comes fully assembled and with interior lighting.



Passenger Station Platform - Item No. 30-9006

Platform Measures: 10" x 3 1/2" x 4"

WHITE PICKET FENCE

SNAPS TOGETHER
QUICKLY AND EASILY

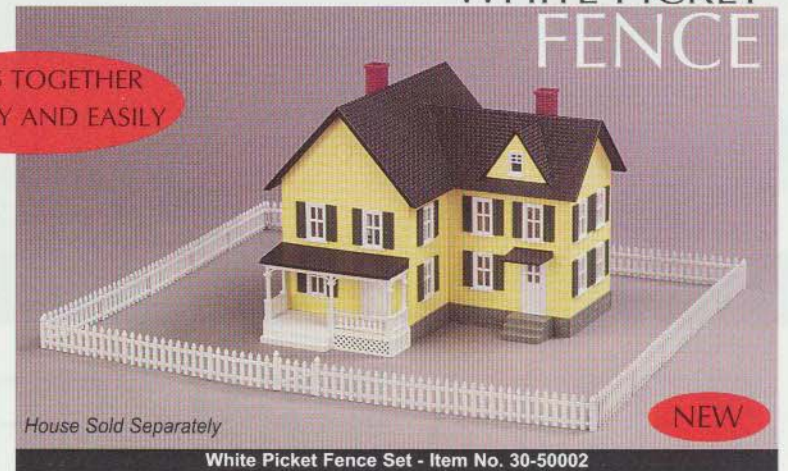

House Sold Separately

White Picket Fence Set - Item No. 30-50002

Fence Set Measures: 16" x 13"

NEW

RITETRAX[®]

BY M.T.H. ELECTRIC TRAINS

MTH RiteTrax[®] is the revolutionary new track design that makes traditional O Gauge track virtually obsolete. Each track section features an authentic roadbed, realistic looking track ties, solid nickel silver rails and quick connectors that eliminate the need for pins that can be lost or bent. RiteTrax[®] is so easy to snap together that a child can set up an oval in minutes. In fact, you can set RiteTrax[®] up anywhere - even on carpet. Best of all, you won't suffer from cut hands, stained carpet or the frustration that today's traditional O Gauge track offers.



RiteTrax[®] Lighted Lockon
Item No. 40-1003

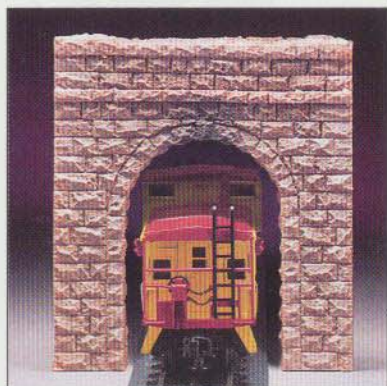
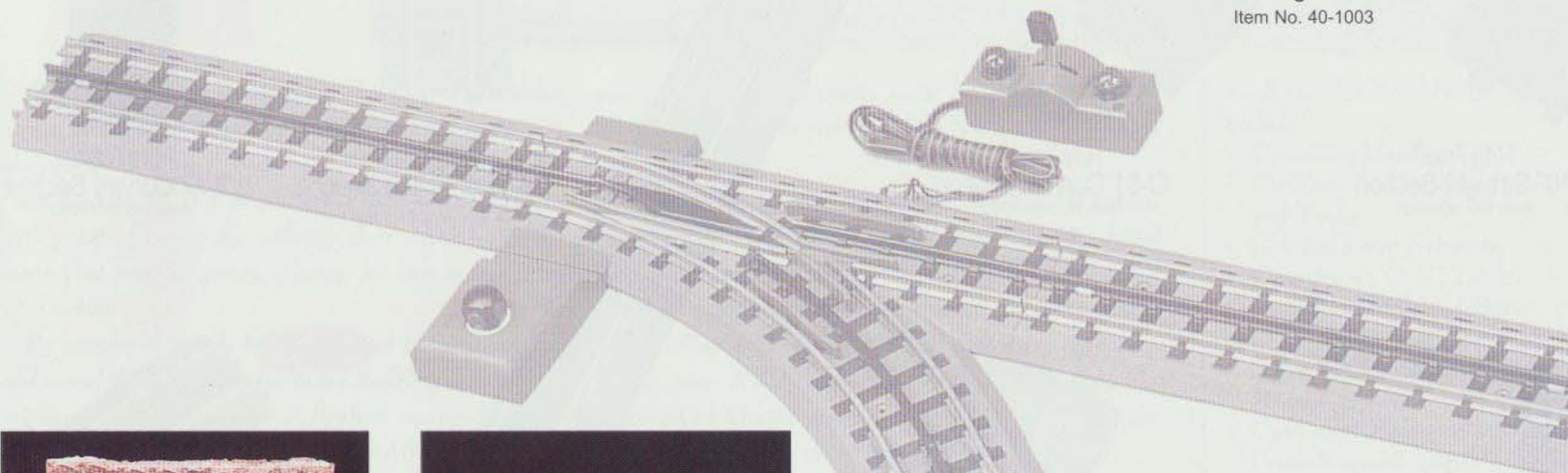

RiteTrax[®]
Single Tunnel Portal

Opening Measures: 4 1/4" W x 5 11/16" H
ABS construction
Item No. 40-9014

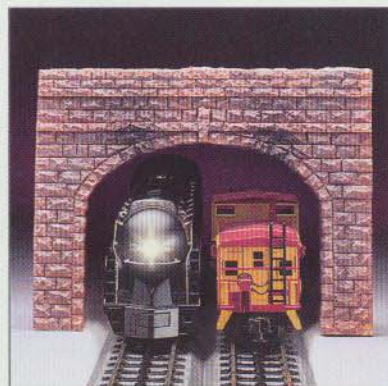

RiteTrax[®]
Double Tunnel Portal

Opening Measures: 7 3/8" W x 5 15/16" H
ABS construction
Item No. 40-9015

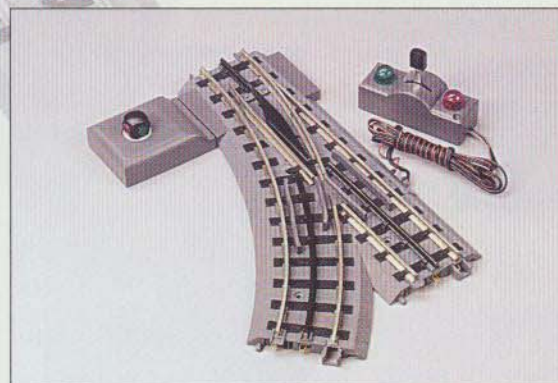

O-31 Switch (L) Item No. 40-1005
O-31 Switch (R) Item No. 40-1004

O-72 Switch (L) Item No. 40-1021
O-72 Switch (R) Item No. 40-1020



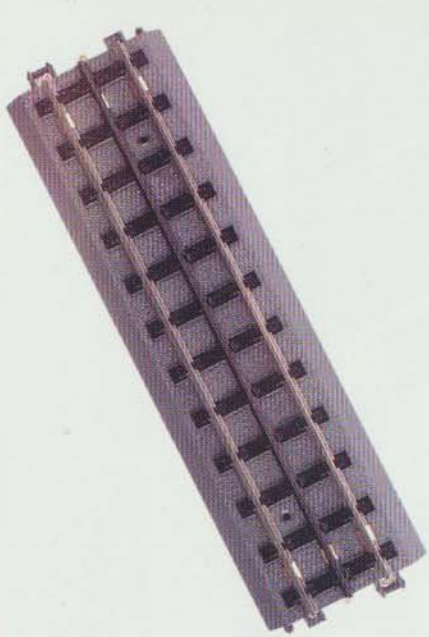

RiteTrax®
10" Straight Section
Item No. 40-1001

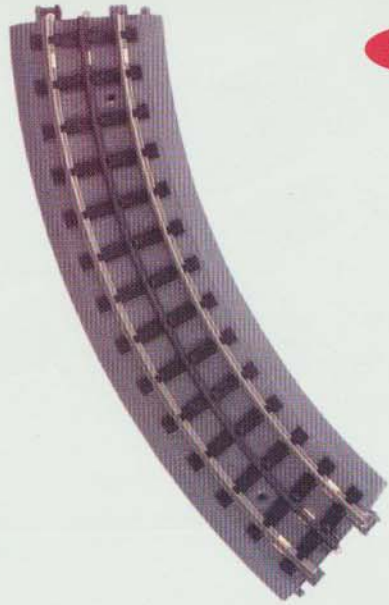

RiteTrax®
O-31 Curved Section
Item No. 40-1002

NEW

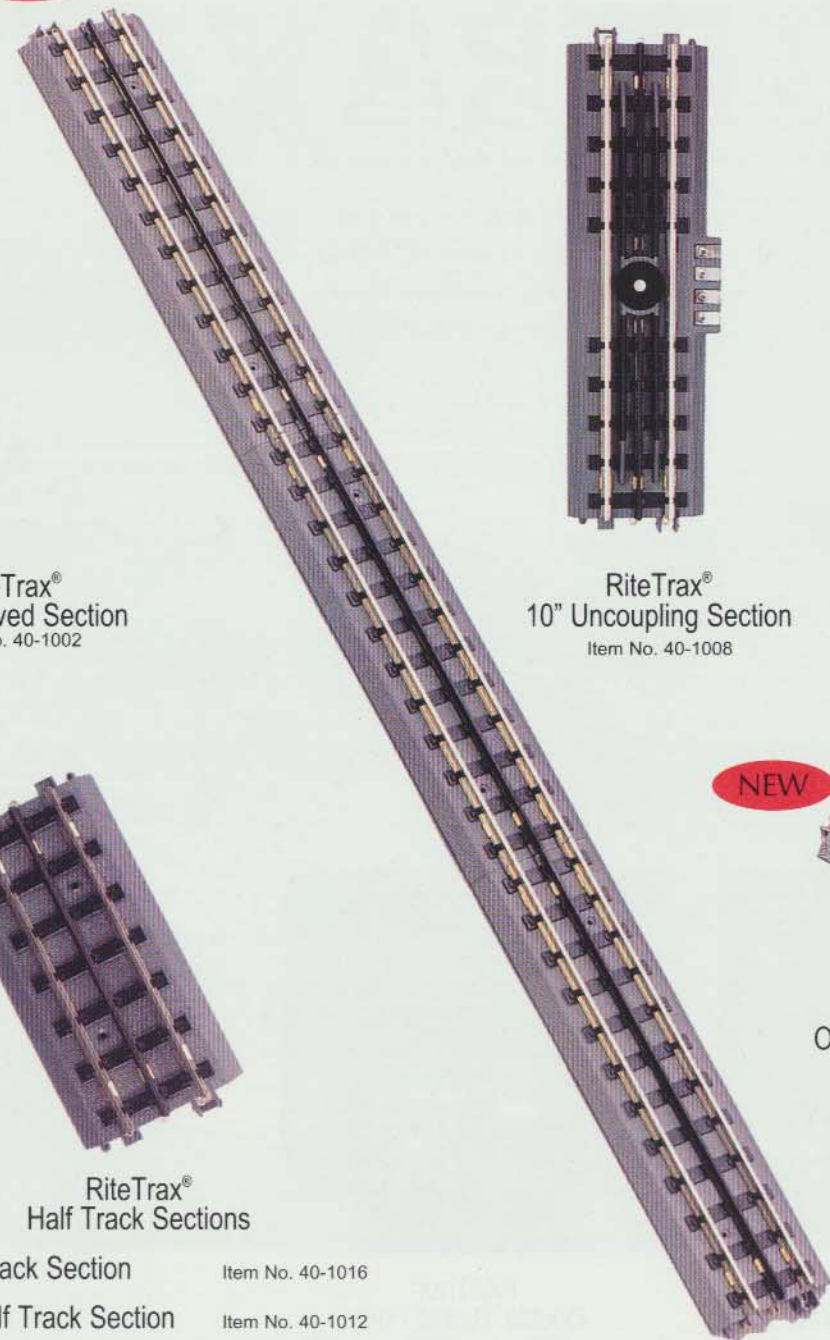

RiteTrax®
10" Uncoupling Section
Item No. 40-1008



RiteTrax®
O-72 Curved Section
Item No. 40-1010

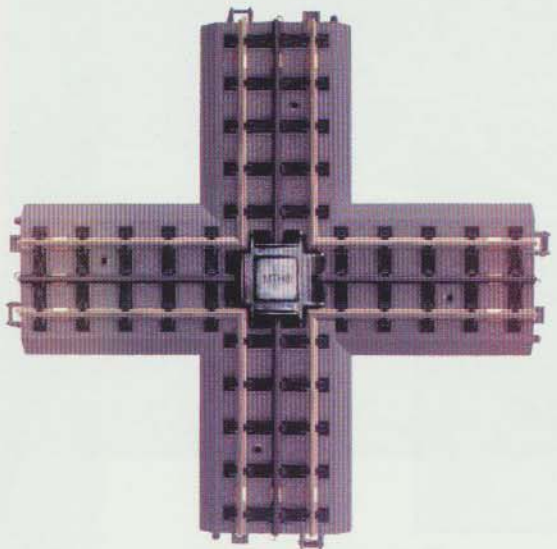

RiteTrax®
90° Crossover
Item No. 40-1006

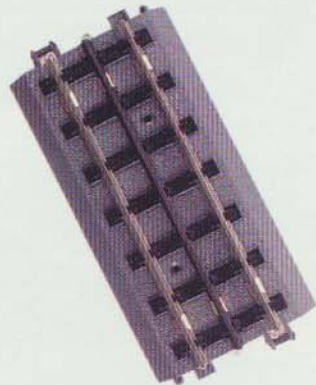

RiteTrax®
Half Track Sections

- 5" Half Track Section Item No. 40-1016
- 5 1/2" Half Track Section Item No. 40-1012
- 4 1/4" Half Track Section Item No. 40-1017
- 3 1/2" Half Track Section Item No. 40-1018

NEW

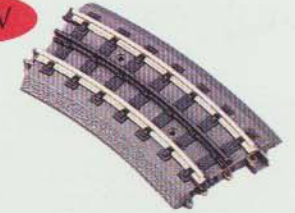

RiteTrax®
O-31 1/2 Curve Section
Item No. 30-1022

RiteTrax®
30" Straight Section
Item No. 40-1019

RITETRAX® TRACK SYSTEM

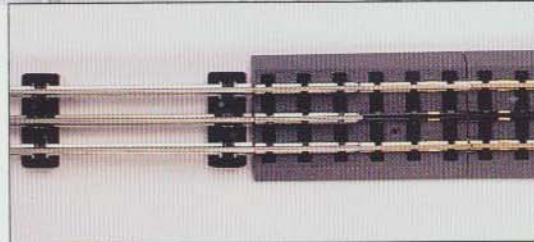
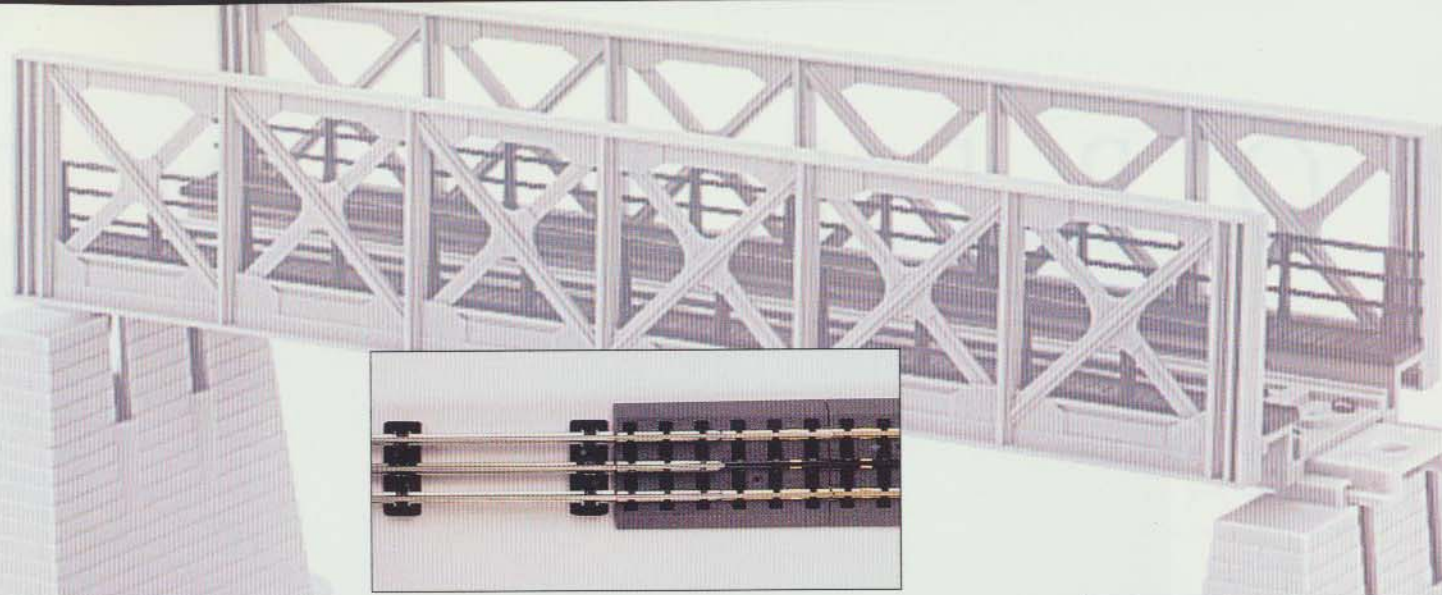

RiteTrax® 5" Adapter Track Section
Item No. 40-1011

PERFECT FOR ALL O GAUGE TRACK SYSTEMS



Girder
Includes 2 ABS stone bridge supports.
Item No. 40-1014
Measures: 10" in length



Bridge
Bridge shown with optional outside girders
Item No. 40-1013
Measures: 30" in length

O P E R A T I N G



Operating Double
Traffic Light Set

Item No. 30-1089-2
Each Light Measures Approximately: 5" Tall

Operating Signal
Traffic Light Set

Item No. 30-1089-1
Each Light Measures Approximately: 5" Tall

TRAFFIC LIGHT SET

More lights and accessories return to our 1998 lineup in full color and durable metal construction. Many full sized lamp and trackside accessories feature stamped metal or die-cast construction.

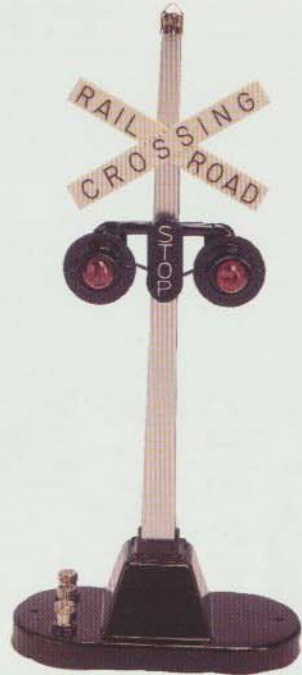

#154 Highway Flashing Signal

Item No. 30-1074
Measures: 8 3/4" Tall



Operating Banjo Signal

Item No. 30-1093
Measures: 8 3/4" Tall



#153 Operating Block Signal

Item No. 30-1076
Measures: 9" Tall

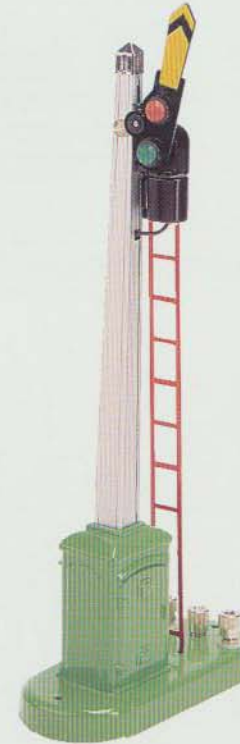

#151 Operating Semaphore

Item No. 30-1075
Measures: 9" Tall



Operating American Flag

Item No. 30-9103

The patented operating American flag, created by former Lionel Trains® designer Frank Petit, features a motor drive that actually waves the flag. With the simple push of a button, the flag will slowly unfurl as if a sudden breeze has caught its surface and stretched it completely outright. As long as the button remains depressed, the flag flutters in the breeze in an incredibly realistic manner that you have to see to believe!

Measures 9 1/2" Tall

A C C E S S O R I E S

RAILKING

OPERATING ACCESSORIES



"O" Operating Crossing Signal

Item No. 30-11006
Measures: 7" Tall and Includes



"O" Operating Block Signal

Item No. 30-11005
Measures: 8" Tall



#262 Crossing Gate/Signal

Item No. 30-1073
Measures: 9" Tall



Operating Street Clock

Item No. 30-1085
Measures Approximately 8" Tall
Blue Comet Blue



Operating Street Clock

Item No. 30-1094
Measures Approximately 8" Tall
Dark Green

The MTH operating street clock features die-cast construction and a real operating quartz clock.



PAGE 51

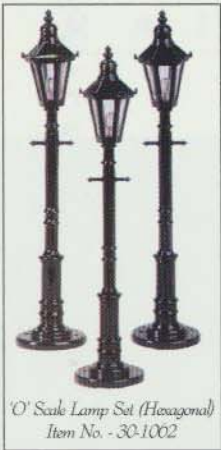

'O' Scale Lamp Set (Hexagonal)
Item No. - 30-1002



'O' Scale Lamp Set (Square)
Item No. - 30-1070

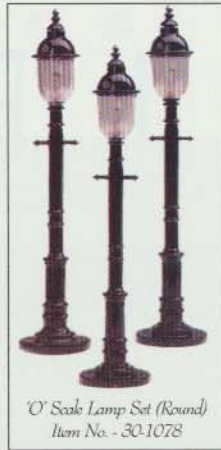

'O' Scale Lamp Set (Round)
Item No. - 30-1078

Each Lamp Measures Almost 4" Tall

#56 Gas Lamp Set

Item No. 30-1098 (Black)
Item No. 30-1069 (Copper)
Measures: 7 3/4" Tall



#59 Gooseneck Lamp Set

Item No. 30-1067 (Cream)
Measures: 8 1/2" Tall

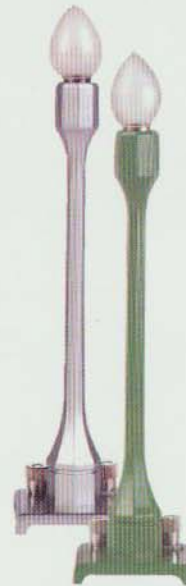

#580-1 Teardrop Lamp Set

Item No. 30-1079A (Pea Green)
Item No. 30-1078A (Silver)
Measures: 8 3/4" Tall



#580-2 Teardrop Lamp Set

Item No. 30-1080A (Pea Green)
Item No. 30-1081A (Maroon)
Item No. 30-1082A (Silver)
Measures: 8 3/4" Tall



#58 Lamp Set

Item No. 30-1090 (Maroon)
Item No. 30-11002 (Dark Green)
Measures: 8 3/4" Tall

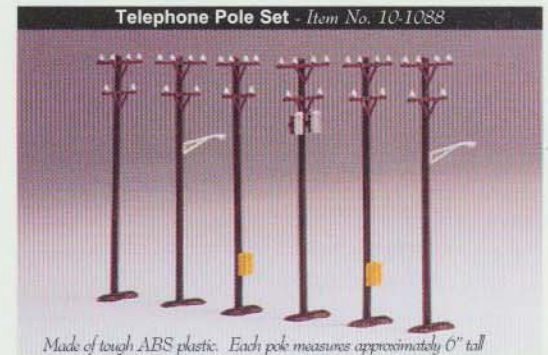

Telephone Pole Set - Item No. 10-1088

Made of tough ABS plastic. Each pole measures approximately 6" tall



Road Sign Set - Item No. 10-1087

Made of tough ABS plastic. 2 each of 7 different signs. Each sign measures approximately 2" tall



ProtoSmoke® - Item No. 00-1045 Coz. bottle

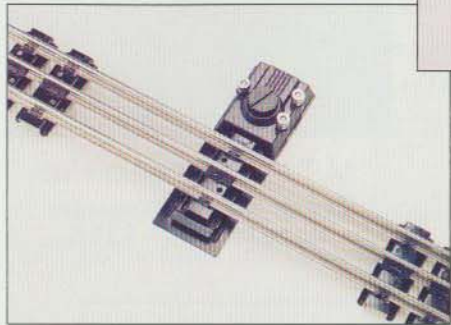

O Gauge T.A.D.
(Track Activation Device)
Item No. 10-1037

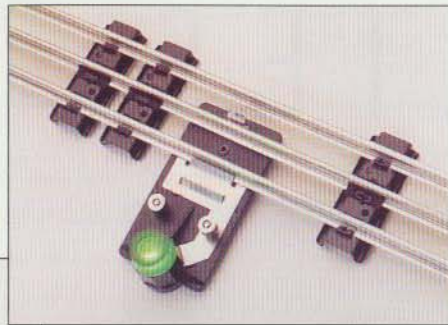

O Gauge Lighted Lockon
Works on tubular
O and Standard Gauge Track
Item No. 10-1021



#64 Highway Lamp Set
Item No. 30-11003 (Black)
Item No. 30-1095 (Silver)
Item No. 30-1065 (Dark Green) not pictured
Measures: 8 3/4" Tall



#57 Corner Lamp Set
Item No. 30-1097 (Cream)
Item No. 30-1068 (Gray)
Measures: 7 1/4" Tall

TRANSFORMER Z-750™



Z-750™ Transformer
Item No. 40-750



RiteTrax®
Wire Harness Set
Item No. 40-1015

A perfect power source for the operator running a single train set or needing power for accessories. Packing 75 watts, the Z-750™ will more than amply power your small to medium sized layout. Bell and horn buttons make it possible to control newer Proto-Sound® Diesel and Electric locomotives.

RAILCESSORIES



RailKing® Circle Clock #2.

Keep time with the new RailKing® clock.

Tough yet flexible plastic casing

Item No. 60-1067

M.T.H. Golf Shirts

Colorful Golf shirts for the O Gauge railroad Operator.

Golf Shirt (M) Item No. 60-1301

Golf Shirt (L) Item No. 60-1302

Golf Shirt (XL) Item No. 60-1303

Golf Shirt (XXL) Item No. 60-1304



RailKing® Back-Lit Sign

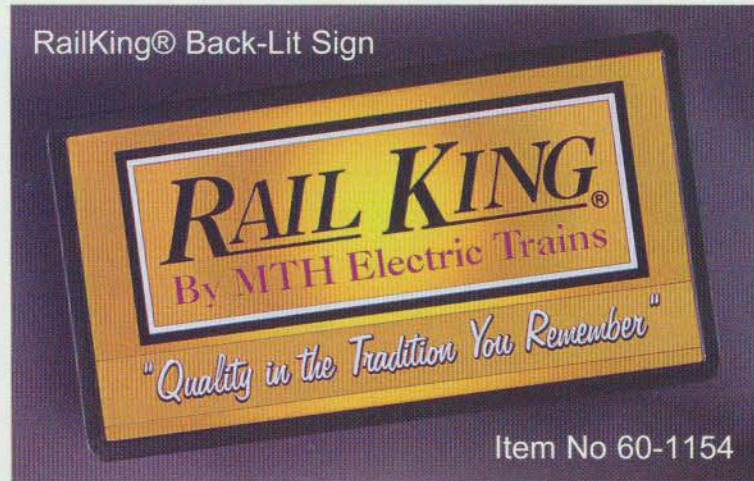

Item No 60-1154



M.T.H. Engineers Hat

Railroad with an engineers hat.

Item No. 60-1316

M.T.H. Back-Lit Sign



Item No 60-1153



RailKing® Mousepad.

Get a RailKing® mousepad for your computer.

Item No. 60-1065

**Great for above your train display.
Hanging hardware included.**

Measures 13" x 25"

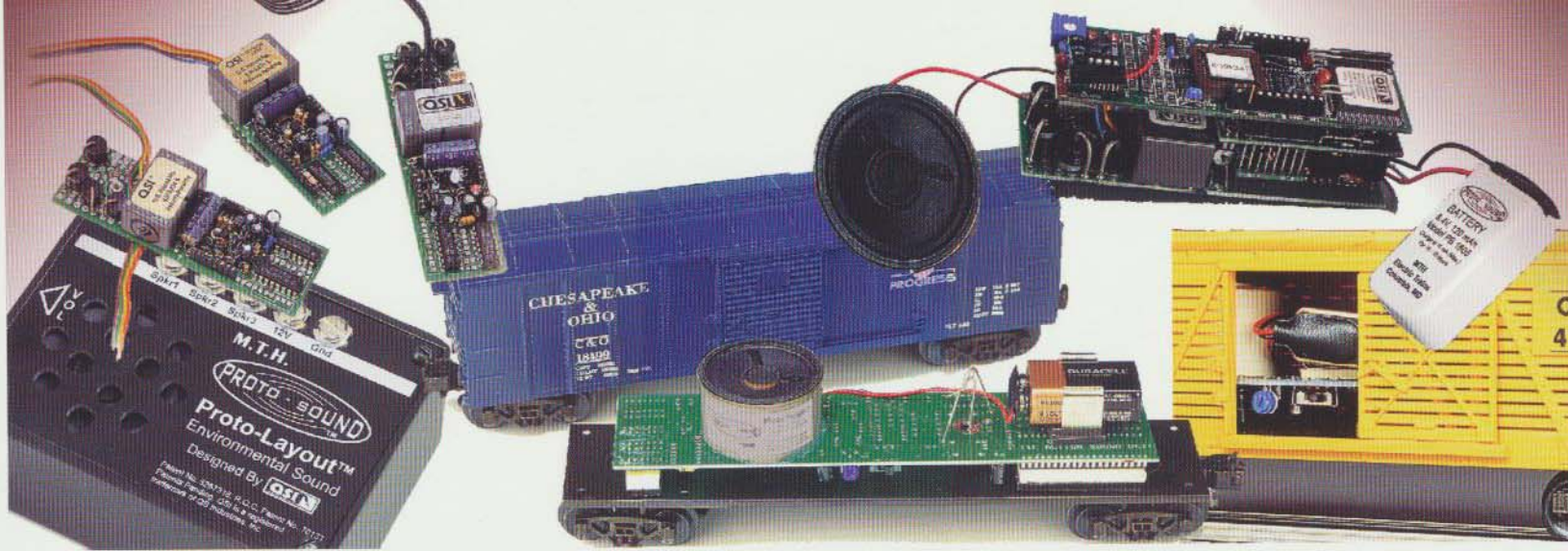

PROTO-LOCO™

DIGITAL SOUND AND TRAIN CONTROL - Now with Proto-Sound® Proto-Loco™ sound modules and reverse units you can retrofit virtually any older standard or O gauge locomotive with a state-of-the-art sound and train control systems, similar to those found in MTH Premier Line and RailKing locomotives. Imagine being able to operate your older locomotives utilizing the same quality sound sets and even more features than those found in today's latest motive power. Thanks to these simple to install systems, those fantasies are now reality.

With two different sound system models and a half-a-dozen reverse units available, you'll find a Proto-Sound® Proto-Loco™ system for virtually any installation application. The Proto-Loco™

ProtoOne System is the most affordable digital sound and train control system available today. This small two-board system plugs into a ProtoSound® DCRU® or ACRU® Electronic Reverse Unit and can be configured with either a generic steam, diesel or electric engine sound set for high quality digital sound reproduction and remote control over engine direction and sound volume right from your transformer.

For those seeking even more features and a wider selection of sound sets, the Proto-Loco® ProtoDeluxe II System can't be beat. Like the ProtoOne, this system features a two-board design that plugs into a Proto-Sound® ACRU® or DCRU® Electronic Reverse Unit. Unlike the ProtoOne, however, the ProtoDeluxe II is compati-

ble with virtually every transformer and operating system available today and can be configured in over two dozen different diesel, steam and electric engine sound sets. In addition, more than two dozen remote control operations are included with each ProtoDeluxe II System giving the operator unprecedented control over his railroad empire.

PROTO-LOCO™ Choose from:

- EMD Diesel • Baldwin Diesel • Alco Diesel • General Electric Diesel • Fairbanks Morse Diesel • GG-1 Electric • Small, Mid-Size & Large Generic Steam Engines • Mid-Size or Large Generic Articulated Steam • S.P. Gs-4 Steam • N&W Northern Steam • Pennsylvania Small & Mid-Size Steam • Pennsy S-2 Turbine and many others.

PROTO-FREIGHT™

SOUND MODULE - Enjoy the wild sounds of our motion-activated Proto-Freight™ digital sound modules. The more your car rocks, the wilder the sound gets!! Choose from twelve different sounds and bring your rolling stock to life.

PROTO-FREIGHT™ Choose from:

- Pigs • Turkeys • Cows • Sheep • Horses • Shifting Freight • Lion • Elephant • Chicken • Monkey • Laughing Santa • Haunted

PROTO-LAYOUT™

ENVIRONMENTAL SOUND - This unique, self-enclosed digital sound module creates a whole new dimension of sound for your layout. Place it anywhere-inside, hidden in scenery, even under the layout. Sound can be activated by battery or layout power.

PROTO-LAYOUT™ Choose from:

- Diesel Idling • Steam Loco at Idle • Christmas Music • Haunted House • Ocean Sounds • Stock Yard • Train Station • Barnyard • Stormy Night • Country Night





For The Dealer Nearest You,
Call Our Toll Free Dealer Locator Number

1-888-640-3700

All products depicted in this catalog are not production models. In some cases, the items pictured may be HO, O Scale or some other scale product. All item's graphic features and content are subject to change after publication. All product features may be verified on their retail packages.

©1998, MTH Electric Trains,
7020 Columbia Gateway Drive,
Columbia, Maryland 21040-1532.
www.mth-railking.com.

MTH Trademarks: MTH Electric Trains®, Proto-Sound®, ProtoSmoke®, Proto-Coupler®, RailKing®, RailTown™, Timplat Traditions™, RiteTrax®, Z-500™, Z-750™, Z-4000™, and the MTH Numbering System and all others indicated throughout this catalog. DCRU®, ACRU®, QSI® are registered trademarks of QS Industries. Ertl is a registered trademark of Ertl Collectibles. Lionel Trains® is a registered trademark of Lionel L.L.C.

